

TM 5-3610-253-14-2

TECHNICAL MANUAL

**OPERATOR'S, ORGANIZATIONAL, DIRECT
SUPPORT AND GENERAL SUPPORT
MAINTENANCE MANUAL**

**TOPOGRAPHIC SUPPORT SYSTEM
FINISHING SECTION
MODEL ADC-TSS-16
NSN 3610-01-105-6443**

This manual together with TM 5-3610-253-14-1 supersedes TM 5-3610-253-14 dated 15 September 1983.

HEADQUARTERS, DEPARTMENT OF THE ARMY

3 SEPTEMBER 1985

WARNING

HIGH VOLTAGE is used in this equipment. DEATH ON CONTACT or sever injury may result of personnel fail to observe safety precautions.

Do not be misled by the term LOW VOLTAGE. Low voltage can cause serious injury or death.

Test procedures requiring the operator or maintenance personnel to investigate equipment or restore casualties with interlocks disconnected or covers removed may result in DEATH ON CONTACT if personnel fail to observe safety precautions.

Voltages in switches and circuit breaker panels may result in DEATH ON CONTACT if personnel fail to observe safety precautions.

Failure to ground the section or equipment may result in DEATH ON CONTACT if personnel fail to observe safety procedures.

For Artificial Respiration refer to FM 21-11.

WARNING

Dry Cleaning solvent P-D-680, used to clean parts, is potentially dangerous to personnel and property. Avoid repeated and prolonged skin contact. Wear solvent-impermeable gloves and eye/face protective equipment when using solvent. Do not use near open flame or excessive heat. Flash point of solvent is 100°F to 138°F (38°C to 59°C).

WARNING

Rotating and spinning equipment may snag loose clothing, hair, or jewelry resulting in SEVERE PERSONNEL INJURY.

WARNING

Attempting to move overweight or top-heavy equipment that is unsecured may result in SEVERE PERSONNEL INJURY. Always have sufficient personnel and equipment to accomplish the task.

Change

No. 5

**Operator's, Unit, Direct Support and General Support
Maintenance Manual
Topographic Support System
Finishing Section, Model ADC-TSS-16
(NSN 3610-01-026-3417) (EIC: N/A)**

REPORTING ERRORS AND RECOMMENDING IMPROVEMENTS

You can help improve this manual. If you find any mistakes, or if you know of a way to improve the procedures, please let us know. We'd prefer that you submit your recommended changes electronically, either by e-mail (AMSEL-LC-LEO-PUBS-CHG@mail1.monmouth.army.mil) or online (<http://edm.monmouth.army.mil/pubs/2028.html>). Alternatively, you may mail or fax your letter, DA Form 2028 (Recommended Changes to Publications and Blank Forms) or DA Form 2028-2 located in back of this manual to: Commander, US Army Communications-Electronics Command and Fort Monmouth, ATTN: AMSEL-LC-LEO-E-ED, Fort Monmouth, NJ 07703-5006. The fax number is 732-532-3421, DSN 992-3421.

In any case, we will send you a reply.

Approved for Public Release; Distribution is Unlimited

TM 5-3610-253-14-2, dated 3 September 1985, is changed as follows:

1. Title of manual is changed as shown above.
2. Appendix B., Maintenance Allocation Chart, has been revised to implement Army Maintenance Transformation and changes the Maintenance Allocation Chart (MAC) to support Field and Sustainment Maintenance. Because the entire Appendix is revised, no change bars/hands are used.

Remove Pages

a/(b Blank)
B-1 through B-13/(B-14 Blank)

Insert Pages

a and b
B-1 through B-12

3. File this change sheet in the front of the publication for reference purposes.

By Order of the Secretary of the Army:

Official:



SANDRA R. RILEY

*Administrative Assistant to the
Secretary of the Army*

0602501

PETER J. SCHOOMAKER
*General, United States Army
Chief of Staff*

To be distributed in accordance with Initial Distribution Number (IDN) 250805 requirements for TM 5-3610-253-14-2.

CHANGE

NO. 4

**HEADQUARTERS
DEPARTMENT OF THE ARMY
WASHINGTON, D.C., 18 MAY 1992**

Operator's, Organizational, Direct Support and
General Support Maintenance Manual

**TOPOGRAPHIC SUPPORT SYSTEM
FINISHING SECTION
MODEL ADC-TSS-16 NSN 3610-01-105-6443**

Approved for public release; distribution is unlimited

TM 5-3610-253-14-2, 3 September 1985, is changed as follows:

1. Remove and insert pages as indicated below. New or changed text material is indicated by a vertical bar in the margin. An illustration change is indicated by a miniature pointing hand.

Remove pages

Insert pages

C-1 and C-2

C-1 and C-2

2. Retain this sheet in front of manual for reference purposes.

By Order of the Secretary of the Army:

Official:

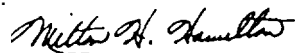

MILTON H. HAMILTON
*Administrative Assistant to the
Secretary of the Army*

01261

GORDON R. SULLIVAN
*General, United States Army
Chief of Staff*

DISTRIBUTION:

To be distributed in accordance with DA Form 12-25E, qty rqr block no. 0805.

CHANGE }
NO. 3 }

HEADQUARTERS
DEPARTMENT OF THE ARMY
WASHINGTON, D. C., 25 July 1988

Operator's, Organizational, Direct Support and
General Support Maintenance Manual

TOPOGRAPHIC SUPPORT SYSTEM
FINISHING SECTION
MODEL ADC-TSS-16
NSN 3610-01-105-6443

TM 5-3610-253-14-2, 3 September 1985, is changed as follows:

1. Remove and insert pages as indicated below. New or changed text material is indicated by a vertical bar in the margin. An illustration change is indicated by a miniature pointing hand.

Remove pages

Insert pages

A-3 and E-4

E-3 and E-4

2. Retain this sheet in front of manual for reference purposes.

By Order of the Secretary of the Army:

CARL E. VUONO
General, United States Army
Chief of Staff

Official:

R. L. DILWORTH
Brigadier General, United States Army
The Adjutant General

DISTRIBUTION:

To be distributed in accordance with DA Form 12-25A, Operator's, Unit, Direct Support and General Support Maintenance requirements for Finishing Section, Topographic Support System, Model ADC-TSS-16.

CHANGE

No. 2

HEADQUARTERS
DEPARTMENT OF THE ARMY
WASHINGTON, D. C., 20 January 1988

Operator's, Organizational, Direct Support and
General Support Maintenance Manual

TOPOGRAPHIC SUPPORT SYSTEM
FINISHING SECTION
MODEL ADC-TSS-16
NSN 3610-01-105-6443

TM 5-3610-253-14-2, 3 September 1985, is changed as follows:

1. Remove and insert pages as indicated below. New or changed text material is indicated by a vertical bar in the margin. An illustration change is indicated by a miniature pointing hand.

Remove pages

6-9 through 6-16/6-17
B-9 and B-10
C-1 and C-2

Insert pages

6-9 and 6-10
B-9 and B-10
C-1 and C-2

2. Retain this sheet in front of manual for reference purposes.

By Order of the Secretary of the Army:

CARL E. VUONO
General, United States Army
Chief of Staff

Official:

R. L. DILWORTH
Brigadier General, United States Army
The Adjutant General

DISTRIBUTION:

To be distributed in accordance with DA Form 12-25A, Operator's, Unit, Direct Support and General Support Maintenance requirements for Finishing Section, Topographic Support System, Model ADC-TTS-16.

CHANGE

No. 1

HEADQUARTERS
DEPARTMENT OF THE ARMY
WASHINGTON, D. C., 8 July 1986

Operator's, Organizational, Direct Support and
General Support Maintenance Manual

TOPOGRAPHIC SUPPORT SYSTEM
FINISHING SECTION
MODEL ADC-TSS-16
NSN 3610-01-105-6443

TM 5-3610-253-14-2, 3 September 1985, is changed as follows:

1. Remove and insert pages as indicated below. New or changed text material is indicated by a vertical bar in the margin. An illustration change is indicated by a miniature pointing hand.

Remove pages

i and ii
B-5 through B-13/B-14
C-1 through C-11/C-12
D-1/D-2
E-1 through E-4

Insert pages

i and ii
B-5 through B-13/B-14
C-1 through C-11/C-12
D-1/D-2
E-1 through E-4
E-5/E-6

2. Retain this sheet in front of manual for reference purposes.

By Order of the Secretary of the Army:

Official:

R. L. DILWORTH
Brigadier General, United States Army
The Adjutant General

JOHN A. WICKHAM, JR.
General, United States Army
Chief of Staff

DISTRIBUTION:

To be distributed in accordance with DA Form 12-25A, Operator's, Organizational, Direct Support and General Support Maintenance requirements for Finishing Section, Topographic Support System, Model ADC-TTS-16.

LIST OF EFFECTIVE PAGES

INSERT LATEST CHANGED PAGES. DESTROY SUPERSEDED PAGES

Dates of issue for original is:

Original	3	September 1985
Change 1	8	July 1986
Change 2	20	January 1988
Change 3	25	July 1988
Change 4	18	May 1992
Change 5.....	1	September 2005

TOTAL NUMBER OF PAGES IN THIS PUBLICATION IS 156 CONSISTING OF THE FOLLOWING:

Page	*Change No.
Cover	0
a and b	5
Introduction/(Blank)	0
i	0
ii	1
6-0 through 6-8	0
6-9 and 6-10	2
7-0 through 7-10	0
8-0 through 8-17	0
9-0 through 9-6	0
A-1 and A-2	0
B-1 through B-12	5
C-1	1
C-2	4
C-3	1
C-4	0
C-5	1
C-6 and C-7	0
C-8 through C-11/(c-12 Blank)	1
D-1/)D-2 Blank)	0
E-1 and E-2	0
E-3 and E-4	3
E-5 and E-6	0
Glossary-1/(Glossary-2 Blank)	0
Index-1 through Index-29/(Index-30 Blank)	0
FP-1/(FP-2 Blank)	0
FP-3/(FP-4 Blank)	0
FP-5/(FP-6 Blank)	0
FP-7/(FP-8 Blank)	0
FP-9/(FP-10 Blank)	0
FP-11/(FP-12 Blank)	0

* Zero in this column indicates an original page.

INTRODUCTION

This manual is divided into two volumes:

Volume I, TM 5-3610-253-14-1, consists of Chapters 1 through Chapter 5.

Volume II, TM 5-3610-253-14-2, consists of Chapters 6 through Chapter 9, Appendixes A through E, Glossary and Index.

The Appendixes and Glossary in Volume II are applicable to both volumes.

Operator's, Organizational, Direct Support and
General Support Maintenance Manual

TOPOGRAPHIC SUPPORT SYSTEM
FINISHING SECTION, MODEL ADC-TSS-16
NSN: 3610-01-105-6443

REPORTING ERRORS AND RECOMMENDING IMPROVEMENTS

You can help improve this manual. If you find any mistakes or if you know of a way to improve the procedures, please let us know. Mail your letter or DA Form 2028 (Recommended Changes to Publications and Blank Forms) or DA Form 2028-2, located in the back of this manual, direct to: U.S. Army Troop Support Command, ATTN: AMSTR-MCTS, 4300 Goodfellow Blvd, St Louis, MO 63120-1798. A reply will be furnished you.

CHAPTER 6	SHRINK WRAP SYSTEM.	6-1
Section I	Introduction.	6-1
Section II	Operating Instructions	6-3
Section III	Operator Maintenance	6-9
Section IV	Organizational Maintenance	6-10
Section V	Direct/General Support Maintenance	6-16
CHAPTER 7	MASON-TYPE PSYCHROMETER	7-1
Section I	Introduction.	7-1
Section II	Operating Instructions	7-2
Section III	Operator Maintenance	7-9
Section IV	Organizational Maintenance	7-10
Section V	Direct/General Support Maintenance	7-10
CHAPTER 8	FURNITURE AND CABINETS	8-1
Section I	Introduction.	8-1
Section II	Operating Instructions	8-3
Section III	Operator Maintenance	8-3
Section IV	Organizational Maintenance	8-4
Section V	Direct/General Support Maintenance	8-17

CHAPTER 9	SUPPORT ITEMS	9-1
Section I	Introduction.	9-1
Section II	Operating Instructions	9-1
Section III	Operator Maintenance	9-5
Section IV	Organizational Maintenance	9-5
Section V	Direct/General Support Maintenance	9-6
APPENDIX A	REFERENCES	A-1
APPENDIX B	MAINTENANCE ALLOCATION CHART	B-1
APPENDIX C	COMPONENTS OF END ITEM AND BASIC ISSUE ITEMS LIST.	C-1
APPENDIX D	ADDITIONAL AUTHORIZATION LIST.	D-1
APPENDIX E	EXPENDABLE/DURABLE SUPPLIES AND MATERIAL LIST.	E-1
GLOSSARY	GLOSSARY 1
INDEX	INDEX-1

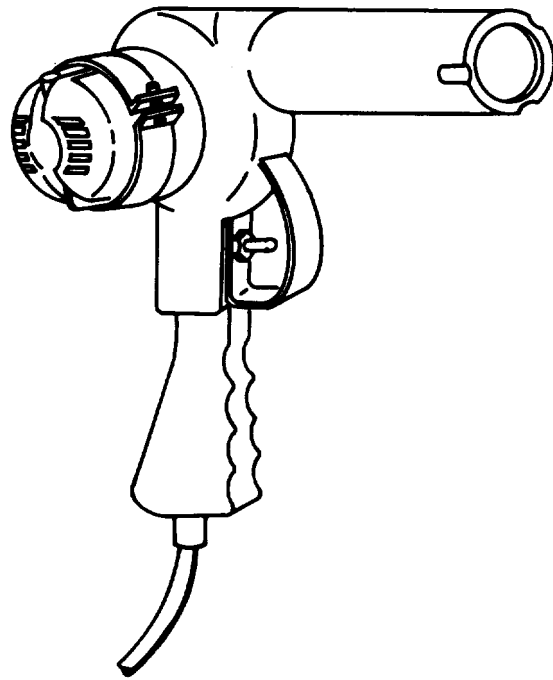

CHAPTER 6
SHRINK WRAP SYSTEM

Section I INTRODUCTION

6-1. GENERAL INFORMATION.

6-1.1 Scope.

- a. Model Number and Equipment Name. Model EP7 Heat Gun.
- b. Purpose of Equipment. To heat shrink wrap on finished products.

6-2. EQUIPMENT DESCRIPTION.

6-2.1 Equipment Characteristics, Capabilities, and Features.

- a. Thermostatically controlled.
- b. Adjustable base.
- c. Variable temperature control.
- d. Can produce heated or unheated airflow.

6-2.2 Location and Description of Major Components.

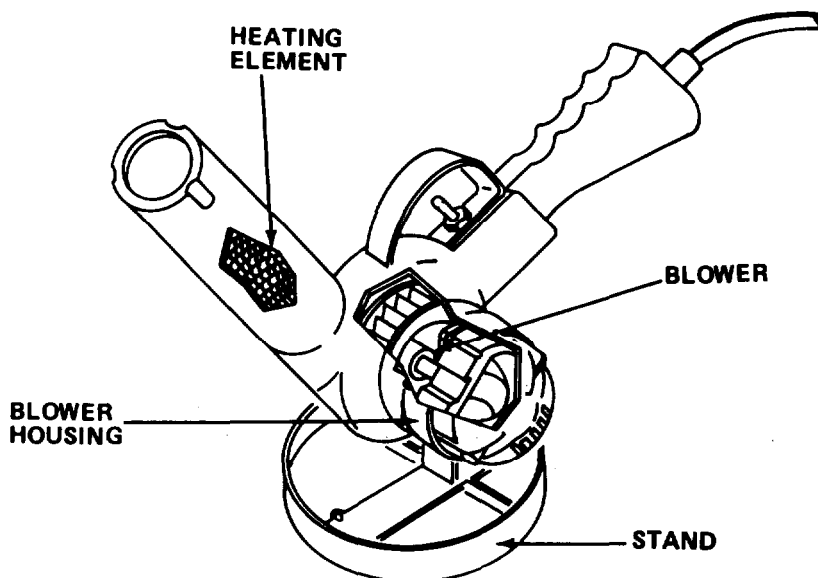

BLOWER HOUSING. Covers and contains blower, blower brushes, control switch, air intake, and air intake flow control.

STAND. Plastic stand is mounted to right blower housing. Stand adjusts to allow nozzle to be pointed in any position from vertical to horizontal.

HEATING ELEMENTS. Radiates heat to warm airflow.

BLOWER. Is driven by electric motor and draws air into adjustable air intake and forces it through heating element and out nozzle.

6-2.3 Equipment Data.

Air Volume	27 CFM
Air Velocity	975 FPM
Nozzle Air Opening	1.19 in. (3.02 cm)
Air Temperature Range	750°-1000°F (399°-538°C)
Weight	2.75 lbs (1.25 Kg)
Voltage	115 V, 50-60 Hz
Current Consumption	19 amps

6-3. TECHNICAL PRINCIPLES OF OPERATION. Technical principles of operation are combined with the description and use of operator's controls and indicators.

Section II OPERATING INSTRUCTIONS

6-4. DESCRIPTION AND USE OF OPERATOR'S CONTROLS AND INDICATORS.

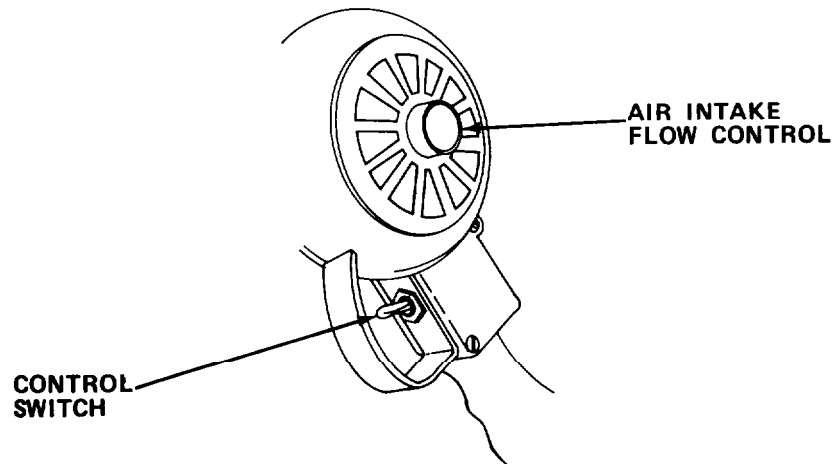

Control or Indicator	Function
Control Switch	<p>OFF: Fan and heating element are off. No air discharged.</p> <p>COLD: Fan is on and heating element is off. Air discharge is not heated.</p> <p>HOT: Fan and heating element are on. Air discharge is heated.</p>
Air Intake Flow Control	<p>Open: Maximum airflow and cooler air temperature.</p> <p>Closed: Less airflow and hotter air temperature.</p>

6-5. OPERATOR PREVENTIVE MAINTENANCE CHECKS AND SERVICES.

- a. Before You Operate. Always keep in mind the WARNINGS and CAUTIONS. Perform you before (B) PMCS.
- b. While You Operate. Always keep in mind the WARNINGS and CAUTIONS. Perform your during (D) PMCS.
- c. After You Operate. Be sure to perform your after (A) PMCS.
- d. If Your Equipment Fails to Operate. Troubleshoot with proper equipment. Report any deficiencies using the proper forms. See DA Pam 738-750.

6-5.1 PMCS Procedures.

- a. PMCS are designed to keep the equipment in good working condition by performing periodic service tasks.
- b. Service intervals provide you, the operator, with time schedules that determine when to perform specified service tasks.
- c. The "Equipment is Not Ready/Available If" column is used for identification of conditions that make the equipment not ready/available for readiness reporting purposes or denies use of the equipment until corrective maintenance is performed.
- d. If your equipment fails to operate after PMCS is performed, immediately report this condition to your supervisor.
- e. Perform weekly as well as before operation if you are the assigned operator and have not operated the item since the last weekly or if you are operating the item for the first time.
- f. Item number column. Item numbers are assigned in chronological ascending sequence regardless of interval designation. These numbers are used for your "TM Number" column on DA Form 2404, Equipment Inspection and Maintenance Worksheet in recording results of PMCS.
- g. Interval columns. This column determines the time period designated to perform your PMCS.
- h. Item to be inspected and procedures column. This column lists functional groups and their respective assemblies and subassemblies as shown in the Maintenance Allocation Chart (Appendix B). The appropriate check or service procedure follows the specific item to be inspected.
- i. Equipment is not ready/available if: column. This column indicates the reason or cause why your equipment is not ready/available to perform its primary mission.

Table 6-1. OPERATOR PREVENTIVE MAINTENANCE CHECKS AND SERVICES

NOTE

If the equipment must be kept in continuous operation, check and service only those items that can safely be checked and serviced without disturbing operation. Make the complete checks and services when the equipment can be shut down.

		B - Before D - During A - After	W - Weekly M - Monthly Q - Quarterly	AN - Annually S - Semiannually BI - Biennially	(Number)- Hundreds of Hours
ITEM NO.	INTERVAL	ITEM TO BE INSPECTED			For Readiness Reporting, Equipment Is Not Ready/ Available If:
		PROCEDURE			
1	B	<p><u>SHRINK WRAP SYSTEM</u></p> <p><u>Inspect.</u></p> <ol style="list-style-type: none"> 1. Unplug power cord. 2. Inspect power cord for fraying, breaks, and damage. 3. Check strap on stand for adjustment/tightness. <p style="text-align: center;"><u>CAUTION</u></p> <p>Failure to start gun on "cold" for 30 seconds can damage heat gun or reduce life of components.</p>			Power cord is frayed or broken.

Table 6-1. OPERATOR PREVENTIVE MAINTENANCE CHECKS AND SERVICES - Cont

B - Before W - Weekly AN - Annually (Number) - Hundreds of Hours
 D - During M - Monthly S - Semiannually
 A - After Q - Quarterly BI - Biennially

ITEM NO.	INTERVAL	ITEM TO BE INSPECTED PROCEDURE	For Readiness Reporting, Equipment Is Not Ready] Available If:
1	B	<p><u>SHRINK WRAP SYSTEM - Cont</u></p> <p><u>Inspect - Cont</u></p>  <p>4. Plug in power cord. Turn control switch to COLD for 30 seconds.</p> <p>5. Turn control switch to HOT. Adjust air intake flow control to change heat level.</p> <p style="text-align: center;"><u>CAUTION</u></p> <p>Failure to turn control switch to "cold" for at least 1 minute after operating heating element can damage heat gun or cause premature failure.</p> <p>6. Turn control switch to COLD for 1 minute.</p>	<p>Heat gun does not heat.</p>

Table 6-1. OPERATOR PREVENTIVE MAINTENANCE CHECKS AND SERVICES - Cont

B - Before
D - During
A - After

W - Weekly
M - Monthly
Q - Quarterly

AN - Annually
S - Semiannually
BI - Biennially

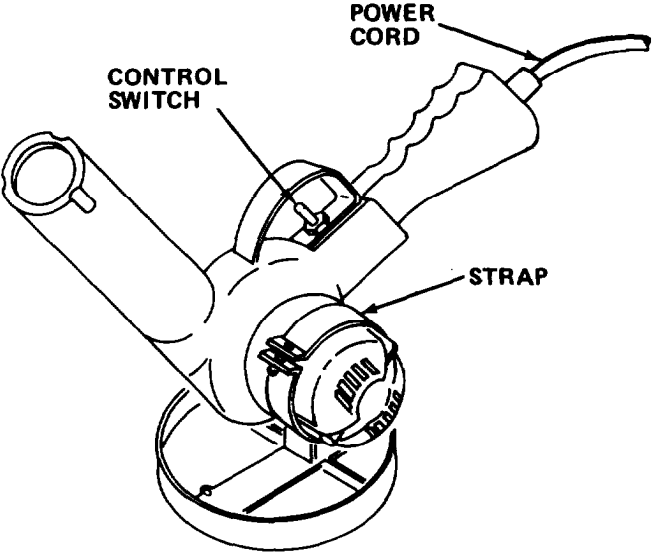
(Number) - Hundreds of Hours

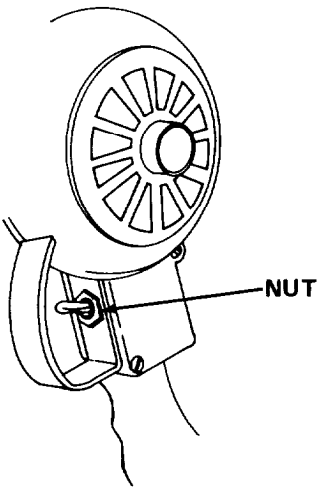
ITEM NO.	INTERVAL	ITEM TO BE INSPECTED PROCEDURE	For Readiness Reporting, Equipment Is Not Ready/ Available If:
<u>SHRINK WRAP SYSTEM - Cont</u>			
1	B	<u>Inspect - Cont</u> 7. Turn control switch to off. 8. Unplug power cord.	
2	B	<u>Service.</u> 	

1. Unplug power cord.
2. Tighten control switch retaining nut.
3. Check that control switch is secure.

6-6. OPERATION UNDER USUAL CONDITIONS.

6-6.1 Operating Procedures.

a. Starting unit.

(1) Move control switch to COLD to start blower motor.

(2) Blower should be allowed to run for 30 seconds to allow unit to stabilize. Then move control switch to HOT. This energizes heating element. Hot air should now be exiting nozzle.

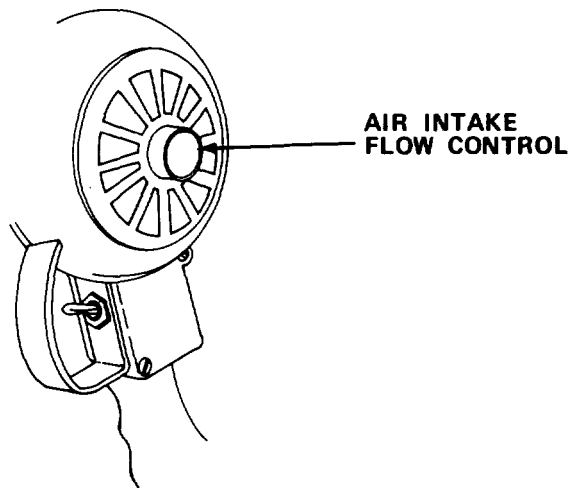

(3) Air temperature can be adjusted by opening (cooler) or closing (hotter) air intake flow control on left blower housing.

CAUTION

Excessive heat may start fire. Do not hold heat gun too close to shrink wrap material.

b. Operating unit. Direct airflow onto clear film and item to be shrink wrapped. Continue only as needed to adequately seal item.

c. Shutting unit down.

(1) Move control switch to COLD. Allow blower fan to run for approximately 1 minute to allow heating element to cool down.

(2) Once heating element has cooled, move control switch to off.

6-7. OPERATION UNDER UNUSUAL CONDITIONS. This equipment is designed for operation only in a controlled environment.

Section III. OPERATOR MAINTENANCE

6-8. LUBRICATION INSTRUCTIONS. This equipment does not require lubrication.

6-9. TROUBLESHOOTING PROCEDURES.

a. The table lists the common malfunctions which you may find during operation or maintenance of the shrink wrap system, You should perform the test/inspections and corrective actions in the order listed.

b. This manual cannot list all malfunctions that may occur, nor all test or inspections and corrective actions. If a malfunction is not listed or is not corrected by listed corrective actions, notify your supervisor.

Table 6-2. TROUBLESHOOTING

MALFUNCTION	TEST OR INSPECTION	CORRECTIVE ACTION
1. BLOWER DOES NOT OPERATE.		
	Step 1. Check for unplugged power cord.	
	(a) If power cord is plugged in, proceed to step 2.	
	(b) Plug in power cord.	
	Step 2. Check for tripped circuit breaker.	
	(a) Reset circuit breaker.	
	(b) Replace unit,	
2. BLOWER BLOWS AIR BUT HEATER DOES NOT OPERATE.		
	Check for tripped heater thermostat.	
	Allow unit to cool for 30 minutes.	

6-10. MAINTENANCE PROCEDURES. There are no operator maintenance procedures assigned for this equipment.

Section IV. ORGANIZATIONAL MAINTENANCE

6-11. LUBRICATION INSTRUCTIONS. This equipment does not require lubrication.

6-12. Deleted.

6-13. SERVICE UPON RECEIPT.

6-13.1 Checking Unpacked Equipment.

a. Inspect the equipment for damage incurred during shipment. If equipment has been damaged, report the damage on DD Form 6, Packing Improvement Report.

b. Check the equipment against the packing list to see if the shipment is complete. Report all discrepancies in accordance with the instructions of DA Pam 738-750.

c. Check to see whether the equipment has been modified.

6-14. ORGANIZATIONAL PREVENTIVE MAINTENANCE CHECKS AND SERVICES. There are no organizational PMCS procedures assigned for this equipment.

Paragraphs 6-15 and 6-16 are deleted.

6-17. PREPARATION FOR STORAGE OR SHIPMENT. Contact your battalion for packing and shipping instructions.

Section V. DIRECT/GENERAL SUPPORT MAINTENANCE

There are no direct/general support maintenance procedures assigned for this equipment.

All data on pages 6-11 through 6-16/6-17 is deleted.

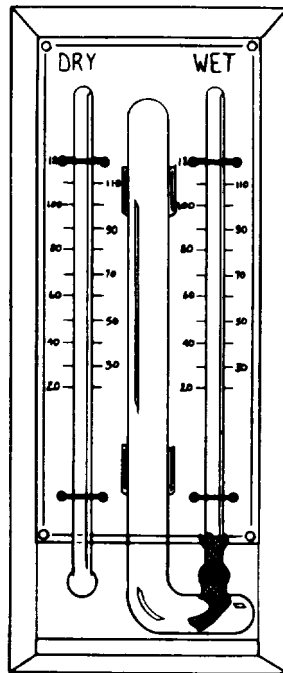

CHAPTER 7

MASON-TYPE PSYCHROMETER

Section I INTRODUCTION

7-1. GENERAL INFORMATION.

7-1.1 Scope.

- a. Model Number and Equipment Name. Model 314 Mason-Type Psychrometer.
- b. Purpose of Equipment. To measure wet and dry bulb temperatures from 20° to 120°F (-6.6° to 48.8°C), for determination of relative humidity.

7-2. EQUIPMENT DESCRIPTION.

7-2.1 Equipment Characteristics, Capabilities, and Features.

- a. Direct reading.
- b. Wall-mounted.

7-2.2 Equipment Data.

Dimensions

Length	9 in. (22.8 cm)
Width	4 in. (10.1 cm)

7-3. TECHNICAL PRINCIPLES OF OPERATION.

a. The mason-type psychrometer is an instrument consisting of two thermometers, used in the measurement of the moisture content (humidity) of air or other gases. The bulb of one of the thermometers is covered by a thin piece of muslin cloth (wick) wetted uniformly with distilled water. The temperatures of both the bulb and the air contacting the bulb are lowered by evaporation which takes place when unsaturated air moves past the wetted bulb. An equilibrium temperature, called the wet-bulb temperature, will be reached; it closely approaches the lowest temperature to which air can be cooled by evaporation of water into that air.

b. The water vapor content of the air surrounding the wet bulb can then be determined by calculating the difference between the wet bulb temperature and the dry bulb temperature. The final determination is known as relative humidity, or the amount of moisture in the air as compared with the maximum amount that the air could contain at the same temperature. Relative humidity is expressed as a percentage. Where the dry bulb and wet bulb temperatures are the same, the atmosphere is saturated.

Section II OPERATING INSTRUCTIONS

7-4. DESCRIPTION AND USE OF OPERATOR'S CONTROLS AND INDICATORS.

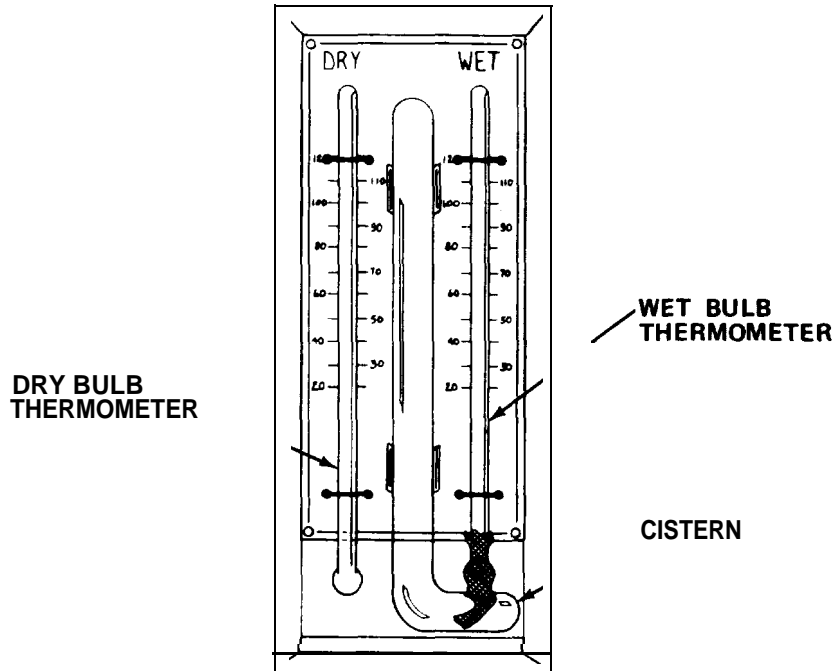

Control or Indicator	Function
WET Bulb Thermometer	Measures temperature of wick in Fahrenheit.
Cistern	Contains water to keep wick on WET bulb thermometer completely saturated.
DRY Bulb Thermometer	Measures air temperature in Fahrenheit.

7-5. OPERATOR PREVENTIVE MAINTENANCE CHECKS AND SERVICES.

- a. Before You Operate. Always keep in mind the WARNINGS and CAUTIONS. Perform you before (B) PMCS.
- b. While You Operate. Always keep in mind the WARNINGS and CAUTIONS. Perform your during (D) PMCS.
- c. After You Operate. Be sure to perform your after (A) PMCS.
- d. If Your Equipment Fails to Operate. Troubleshoot with proper equipment. Report any deficiencies using the proper forms. See DA Pam 738-750.

7-5.1 PMCS Procedures.

- a. PMCS are designed to keep the equipment in good working condition by performing periodic service tasks.
- b. Service intervals provide you, the operator, with time schedules that determine when to perform specified service tasks.
- c. The "Equipment is Not Ready/Available If" column is used for identification conditions that make the equipment not ready/available for readiness reporting purposes or denies use of the equipment until corrective maintenance is performed.
- d. If your equipment fails to operate after PMCS is performed, immediately report this condition to your supervisor.
- e. Perform weekly as well as before operation if you are the assigned operator and have not operated the item since the last weekly or if you are operating the item for the first time.
- f. Item number column. Item numbers are assigned in chronological ascending sequence regardless of interval designation. These numbers are used for your "TM Number" Column on DA Form 2404, Equipment Inspection and Maintenance Worksheet in recording results of PMCS.
- g. Interval columns. This column determines the time period designated to perform your PMCS.
- h. Item to be inspected and procedures column. This column lists functional groups and their respective assemblies and subassemblies as shown in the Maintenance Allocation Chart (Appendix B). The appropriate check or service procedure follows the specific item to be inspected.
- i. Equipment is not ready/available if: column. This column indicates the reason or cause why your equipment is not ready/available to perform its primary mission.

Table 7-1. OPERATOR PREVENTIVE MAINTENANCE CHECKS AND SERVICES

NOTE

If the equipment must be kept in continuous operation, check and service only those items that can safely be checked and serviced without disturbing operation. Make the complete checks and services when the equipment can be shut down.

B - Before W - Weekly AN - Annually (Number) - Hundreds of Hours
 D - During M - Monthly S - Semiannually
 A - After Q - Quarterly BI - Biennially

ITEM NO.	INTERVAL	ITEM TO BE INSPECTED PROCEDURE	For Readiness Reporting, Equipment Is Not Ready/ Available If:
1	W	<p><u>MASON-TYPE PSYCHROMETER</u></p> <p><u>Inspect.</u></p> <ol style="list-style-type: none"> 1. Inspect thermometers for damage. 2. Check that wick is clean and completely saturated with distilled water. 3. Check that cistern is filled with distilled water. <p style="text-align: center;"><u>CAUTION</u></p> <p>Mounting psychrometer near heat sources, fans, or air conditioning supply and exhaust vents will cause psychrometer to indicate incorrect air temperatures.</p> <ol style="list-style-type: none"> 4. Mount psychrometer on wall. 	<p>Thermometers are damaged.</p> <p>Cistern is dry.</p>

Table 7-1. OPERATOR PREVENTIVE MAINTENANCE CHECKS AND SERVICES - Cont

B - Before
D - During
A - After

W - Weekly
M - Monthly
Q - Quarterly

AN - Annually
S - Semiannually
BI - Biennially

(Number) - Hundreds of Hours

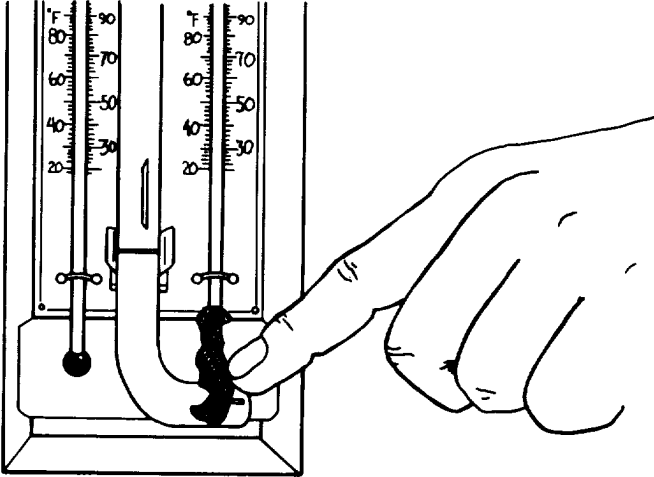
ITEM NO.	INTERVAL	ITEM TO BE INSPECTED PROCEDURE	For Readiness Reporting, Equipment Is Not Ready/ Available If:
2	AN	<p><u>MASON-TYPE PSYCHROMETER - Cont</u></p> <p><u>Replace Wick.</u></p> <ol style="list-style-type: none"> 1. Remove psychrometer from wall.  <ol style="list-style-type: none"> 2. Remove wick from WET bulb thermometer and cistern. 3. Install new wick over WET bulb thermometer. 4. Fill cistern with clean, distilled water. 5. Insert other end of wick into cistern. 6. Saturate wick with distilled water. 7. Mount psychrometer on wall. 	

7-6. OPERATION UNDER USUAL CONDITIONS.

NOTE

Be sure psychrometer is not close to fans, heaters, open doors, and ventilation ducts.

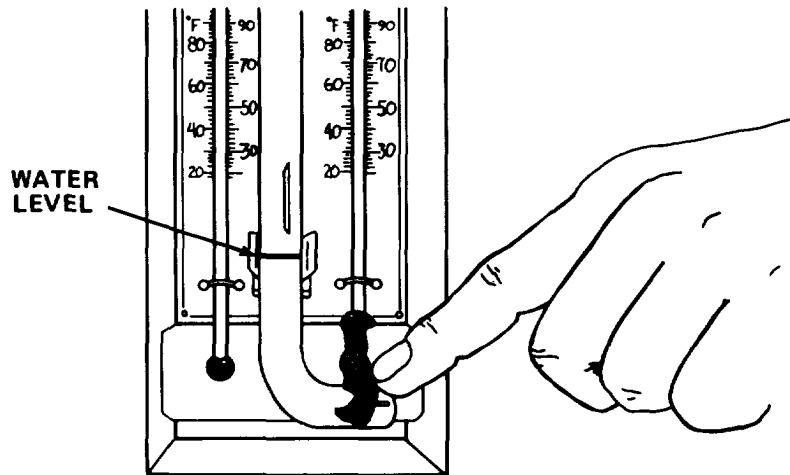

- Check that water level in cistern is halfway between brackets.
- Add distilled water to saturate wick and fill cistern when necessary.
- Mount psychrometer on hook on wall.
- Wait five minutes before recording WET and DRY bulb readings.
- Convert WET and DRY bulb thermometer readings to relative humidity as follows:

Air Temperature (DRY Bulb): 68°F

WET Bulb: 62° F

$$\text{Depression} = \text{DRY Bulb } (t) - \text{WET Bulb } (t') = 68^\circ - 62^\circ = 6^\circ$$

Depression = 6°F

Use left column to find air temperature of 68°F.

Use top column to find depression of 6°F.

The intersection of both columns gives the percent of relative humidity, in this case 71%.

Table 4-2. RELATIVE HUMIDITY, PER CENT - FAHRENHEIT TEMPERATURES - Cont

PRESSURE EQUALS 30.0 INCHES

AIR TEMP	DEPRESSION OF MET-BULB THERMOMETER t-t1																					
t	11.0	11.5	12.0	12.5	13.0	13.5	14.0	14.5	15.0	15.5	16.0	16.5	17.0	17.5	18.0	18.5	19.0	19.5	20.0	20.5	21.0	
35	2																					
36	5	1																				
37	7	3																				
38	10	6	2																			
39	12	9	5	1																		
40	16	11	7	4	0																	
41	17	13	10	6	3																	
42	19	16	12	9	5	2																
43	21	18	14	11	8	4	1															
44	23	20	16	13	10	7	4	0														
45	25	22	18	15	12	9	6	3														
46	26	23	20	17	14	11	8	5	2													
47	28	25	22	19	16	13	10	7	5	2												
48	29	26	23	21	18	15	12	9	7	4	1											
49	31	28	25	22	19	17	14	11	9	6	3	1										
50	32	29	27	24	21	18	16	13	10	8	5	3	0									
51	34	31	28	26	23	20	17	15	12	9	7	4	2									
52	35	32	29	27	24	22	19	17	14	11	9	6	4	1								
53	36	33	31	28	26	23	20	18	16	13	10	8	6	3	1							
54	37	35	32	29	27	24	22	20	17	15	12	10	8	5	3	1						
55	38	36	33	31	28	26	23	21	19	16	14	12	9	7	5	2	0					
56	39	37	34	32	30	27	25	22	20	18	16	14	11	9	7	4	2					
57	40	38	35	33	31	28	26	24	22	19	17	15	13	10	8	6	4	2				
58	41	39	37	34	32	30	27	25	23	21	18	16	14	12	10	8	6	3	1			
59	42	40	38	35	33	31	29	26	24	22	20	18	16	13	11	9	7	5	3	1		
60	43	41	39	37	34	32	30	28	26	23	21	19	17	15	13	11	9	7	5	3	1	
61	44	42	40	38	35	33	31	29	27	25	22	20	18	16	14	12	10	8	7	5	3	
62	45	43	41	39	36	34	32	30	28	26	24	22	20	18	16	14	12	10	8	6	4	
63	46	44	42	40	37	35	33	31	29	27	25	23	21	19	17	15	13	11	10	8	6	
64	47	45	43	41	38	36	34	32	30	28	26	24	22	20	18	17	15	13	11	9	7	
65	48	46	44	41	39	37	35	33	31	29	27	25	24	22	20	18	16	14	12	11	9	
66	48	46	44	42	40	38	36	34	32	30	29	27	25	23	21	19	17	16	14	12	10	
67	49	47	45	43	41	39	37	35	33	31	30	28	26	24	22	20	19	17	15	13	12	
68	50	48	46	44	42	40	38	36	34	32	31	29	27	25	23	21	20	18	16	15	13	
69	51	49	47	45	43	41	39	37	35	33	32	30	28	26	24	23	21	19	18	16	14	
70	51	49	48	46	44	42	40	38	36	34	33	31	29	27	25	24	22	20	19	17	15	
71	52	50	48	46	45	43	41	39	37	35	33	32	30	28	27	25	23	22	20	18	17	
72	53	51	49	47	45	43	42	40	38	36	34	33	31	29	28	26	24	23	21	19	18	
73	53	51	50	48	46	44	42	40	39	37	35	34	32	30	29	27	25	24	22	20	19	
74	54	52	50	48	47	45	43	41	39	38	36	34	33	31	29	28	26	26	23	21	20	

7-7. OPERATION UNDER UNUSUAL CONDITIONS. This equipment is designed for operation only in a controlled environment.

Section III OPERATOR MAINTENANCE

7-8. LUBRICATION INSTRUCTIONS. This equipment does not require lubrication.

7-9. TROUBLESHOOTING PROCEDURES.

a. The table lists the common malfunctions which you may find during the operation or maintenance of the Mason-type psychrometer. You should perform the test/inspection and corrective actions in the order listed.

b. This manual cannot list all malfunctions that may occur, nor all test or inspections and corrective actions. If a malfunction is not listed or is not corrected by listed corrective actions, notify your supervisor.

Table 7-3. TROUBLESHOOTING

MALFUNCTION	TEST OR INSPECTION	CORRECTIVE ACTION
1. WET AND DRY BULB TEMPERATURE READINGS ARE CONSTANTLY IDENTICAL.	Lack of water in cistern.	Add distilled water.
2. WET BULB READINGS DO NOT AGREE WITH OTHER PSYCHROMETERS.	Step 1. Dirty wick. Clean cistern, replace wick, and add distilled water.	Step 2. Thermometer(s) have shifted on scale. Replace psychrometer.

7-10. MAINTENANCE PROCEDURES. There are no operator maintenance procedures assigned for this equipment.

Section IV ORGANIZATIONAL MAINTENANCE

7-11. LUBRICATION INSTRUCTIONS. This equipment does not require lubrication.

7-12. REPAIR PARTS, SPECIAL TOOLS; TEST, MEASUREMENT, AND DIAGNOSTIC EQUIPMENT (TMDE); AND SUPPORT EQUIPMENT.

7-12.1 Common Tools and Equipment. For authorized common tools and equipment, refer to the Modified Table of Organization and Equipment (MTOE) applicable to your unit.

7-12.2 Special Tools; Test, Measurement, and Diagnostic Equipment; and Support Equipment. Special Tools, TMDE, and Support Equipment is listed in the applicable repair parts and special tools list and in Appendix B of this manual.

7-12.3 Repair Parts. Repair parts are listed and illustrated in the Repair Parts and Special Tools List, TM 5-3610-253-24P, covering organizational maintenance for this equipment.

7-13. SERVICE UPON RECEIPT.

7-13.1 Checking Unpacked Equipment.

a. Inspect the equipment for damage incurred during shipment. If the equipment has been damaged, report the damage on DD Form 6, Packing Improvement Report.

b. Check the equipment against the packing list to see if the shipment is complete. Report all discrepancies in accordance with the instructions of DA Pam 738-750.

c. Check to see whether the equipment has been modified.

7-14. ORGANIZATIONAL PREVENTIVE MAINTENANCE CHECKS AND SERVICES. There are no organizational PMCS procedures assigned for this equipment.

7-15. ORGANIZATIONAL TROUBLESHOOTING PROCEDURES. There are no organizational troubleshooting procedures assigned for this equipment.

7-16. MAINTENANCE PROCEDURES. There are no organizational maintenance procedures assigned for this equipment.

7-17. PREPARATION FOR STORAGE OR SHIPMENT. Contact your battalion for packing and shipping instructions.

Section V DIRECT/GENERAL SUPPORT MAINTENANCE

There are no assigned direct/general support maintenance tasks for this equipment.

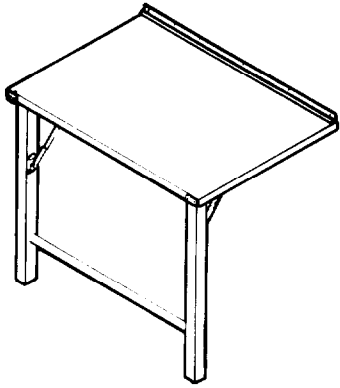

**FOLDING
TABLE**

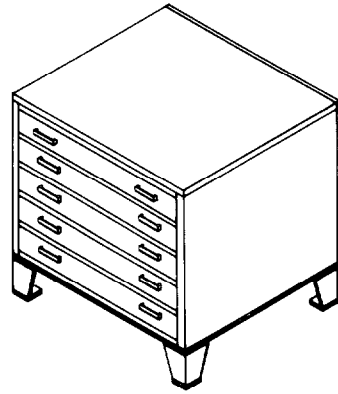

**FIVE DRAWER
PHOTOLITHOGRAPHIC
CABINET**

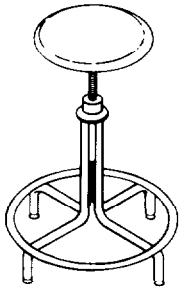

**REVOLVING
STOOL**

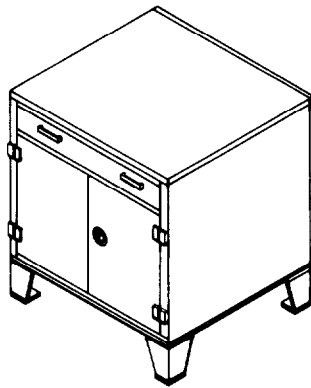

**ONE DRAWER
PHOTOLITHOGRAPHIC
CABINET**

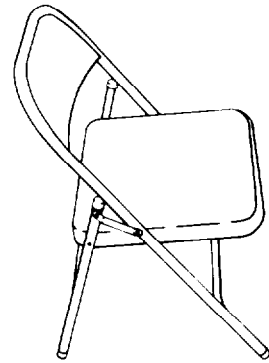

**FOLDING
CHAIR**

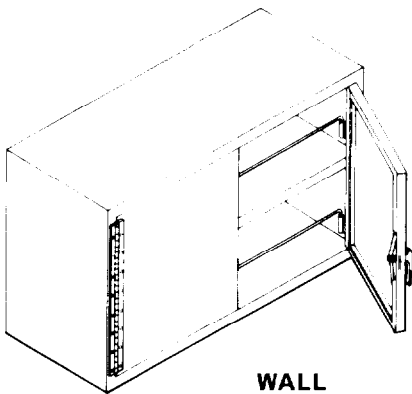

**WALL
STORAGE
CABINET**

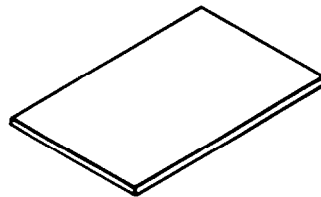

CORKBOARD

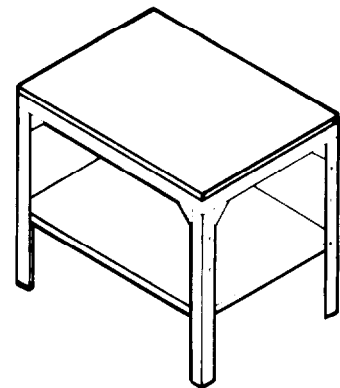

**BINDERY
TABLE**

CHAPTER 8

FURNITURE AND CABINETS

Section I INTRODUCTION

8-1. GENERAL INFORMATION.

8-1.1 Scope. This chapter contains the description of all furniture and cabinets contained in this section.

8-2. EQUIPMENT DESCRIPTION.

Folding table. Provides a general work space. It attaches to a wall and can be folded up flat against the wall. Two fold-out legs provide support for the front of the Table. Dimensions:

Width	42 in. (106.68 cm)
Depth	30.06 in. (76.35 cm)
Height	34.41 in. (87.4 cm)

b. Bindery table. Provides a work space for binding operations. Dimensions:

Width	35 in. (88.9 cm)
Depth	25.38 in. (64.47 cm)
Height	31.88 in. (80.97 cm)

c. Wall storage cabinet. Used for miscellaneous storage. There are two shelves. The two doors are held shut by a handle-type latch. Dimensions:

Width	30 in. (76.2 cm)
Depth	12 in. (30.48 cm)
Height	18 in. (45.72 cm)

d. One drawer photolithographic cabinet. Used for the storage of photolithographic materials and supplies. The cabinet has one sliding drawer mounted atop a double door cabinet. The two cabinet doors are held shut by a flush-type latch. Dimensions:

Width	32.12 in. (81.59 cm)
Depth	28.12 in. (71.42 cm)
Height	40.5 in. (102.87 cm)

e. Five drawer photolithographic cabinet. Used for the storage of photolithographic materials and supplies. The cabinet has five sliding drawers. Dimensions:

Width	35.12 in. (89.20 cm)
Depth	31.12 in. (79.04 cm)
Height	34.5 in. (87.63 cm)

f. Revolving stool. Provides seating for personnel working at equipment. It has adjustable height. Dimensions:

Height	28 in. (71.12 cm), Max. 22.75 in. (57.79 cm), Min.
--------	---

g. Folding chair. Provides general seating. Folds flat for storage. Dimensions:

Width	18 in. (45.72 cm)
Depth	20 in. (50.8 cm)
Height	32 in. (81.28 cm)

h. Corkboard. Wall mounted. Dimensions:

Width	30.0 in. (76.2 cm)
Height	18.0 in. (45.7 cm)

8-3. TECHNICAL PRINCIPLES OF OPERATION. There are no specific principles of operation for this equipment.

Section II OPERATING INSTRUCTIONS

8-4. DESCRIPTION AND USE OF OPERATOR'S CONTROLS AND INDICATORS. This equipment has no operator's controls or indicators.

8-5. OPERATOR PREVENTIVE MAINTENANCE CHECKS AND SERVICES. There are no operator PMCS procedures assigned for this equipment.

8-6. OPERATION UNDER USUAL CONDITIONS.

8-6.1 Preparation for Movement. Ensure that portable equipment is properly secured with tiedowns provided.

8-7. OPERATION UNDER UNUSUAL CONDITIONS. This equipment is designed for operation only in a controlled environment.

Section III OPERATOR MAINTENANCE

8-8. LUBRICATION INSTRUCTIONS. This equipment does not require lubrication.

8-9. TROUBLESHOOTING PROCEDURES. There are no operator troubleshooting procedures assigned for this equipment.

8-10. MAINTENANCE PROCEDURES.

This section contains instructions covering operator maintenance functions for the furniture and cabinets. Personnel required are listed only if the task requires more than one.

b. After completing each maintenance procedure, perform operational check to be sure that equipment is properly functioning.

8-10.1 Inspect Furniture and Cabinets. Inspect furniture and cabinets for structural damage, rust, and proper operation of all latches, hinges, drawer slides, and adjustment mechanisms.

Section IV ORGANIZATIONAL MAINTENANCE

8-11. LUBRICATION INSTRUCTIONS. This equipment does not require lubrication.

8-12. REPAIR PARTS, SPECIAL TOOLS; TEST, MEASUREMENT, AND DIAGNOSTIC EQUIPMENT (TMDE); AND SUPPORT EQUIPMENT.

8-12.1 Common Tools and Equipment. For authorized common tools and equipment, refer to the Modified Table of Organization and Equipment (MTOE) applicable to your unit.

8-12.2 Special Tools; Test, Measurement, and Diagnostic Equipment; and Support Equipment. Special Tools, TMDE, and Support Equipment is listed in the applicable repair parts and special tools list and in Appendix B of this manual.

8-12.3 Repair Parts. Repair parts are listed and illustrated in the Repair Parts and Special Tools List, TM 5-6675-253-24P covering organizational maintenance for this equipment.

8-13. SERVICE UPON RECEIPT.

8-13.1 Checking Unpacked Equipment.

a. Inspect the equipment for damage incurred during shipment. If the equipment has been damaged, report the damage on DD Form 6, Packing Improvement Report.

b. Check the equipment against the packing list to see if the shipment is complete. Report all discrepancies in accordance with the instructions of DA Pam 738-750.

c. Check to see whether the equipment has been modified.

8-14. ORGANIZATIONAL PREVENTIVE MAINTENANCE CHECKS AND SERVICES. There are no organizational PMCS procedures assigned for this equipment.

8-15. ORGANIZATIONAL TROUBLESHOOTING PROCEDURES. There are no organizational troubleshooting procedures assigned for this equipment.

8-16. MAINTENANCE PROCEDURES.

This section contains instructions covering organizational maintenance functions for the furniture and cabinets. Personnel required are listed only if the task requires more than one.

b. After completing each maintenance procedure, perform operational check to be sure that equipment is properly functioning.

INDEX

PROCEDURE	PARAGRAPH
Remove/Install Wall Storage Cabinet	8-16.1
Replace Door Latch (Wall Storage Cabinet)	8-16.2
Replace Door Hinge (Piano Hinge).	8-16.3
Replace Latch (Flush Type)	8-16.4
Replace Hinge.	8-16.5
Replace Leg Supports	8-16.6
Remove/Install Corkboard	8-16.7
Remove/Install Bindery Table	8-16.8
Remove/Install Folding Table	8-16.9
Remove/Install Five Drawer Photolithographic Cabinet	8-16.10
Remove/Install One Drawer Photolithographic Cabinet	8-16.11

8-16.1 Remove/Install Wall Storage Cabinet.

MOS: 83FJ6, Reproduction Equipment Repairer

TOOLS: 1/2 in. Drive Ratchet
2 in. Socket Extension, 1/2 in. Drive
1/2 in. Socket, 1/2 in. Drive

SUPPLIES: Wall Storage Cabinet

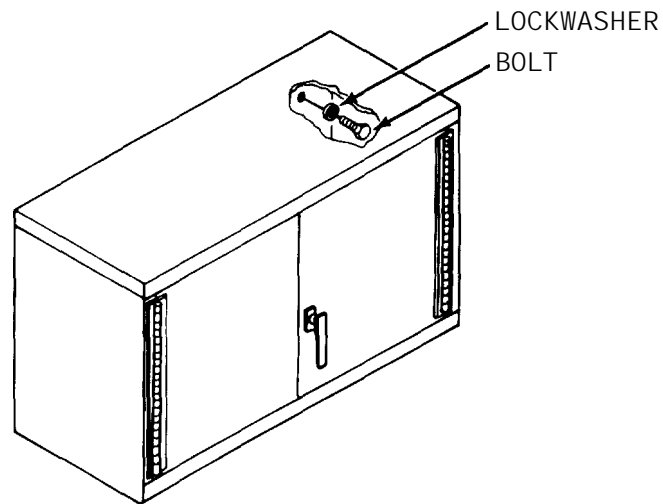

- a. Remove bolts and lockwashers which secure defective cabinet to wall.
- b. Remove defective cabinet.
- c. Install new cabinet and secure to wall with lockwashers and bolts.

8-16.2 Replace Door Latch (Wall Storage Cabinet)

MOS: 83FJ6, Reproduction Equipment Repairer

TOOLS: 9/16 in. Combination Wrench
Flat Tip Screwdriver

SUPPLIES: Handle Type Latch

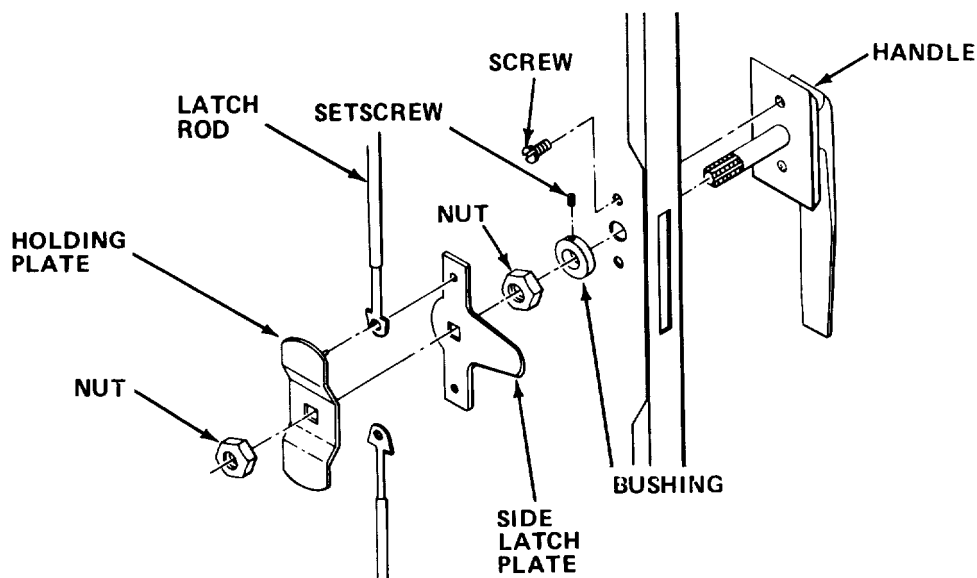

- a. Remove holding plate retaining nut.
- b. Remove holding plate and latch rods.
- c. Remove side latch plate.
- d. Remove handle retaining nut.
- e. Loosen setscrew and remove bushing from handle shaft.
- f. Remove handle retaining screws and remove handle.
- g. Install new handle and secure with screws.
- h. Reinstall bushing on handle shaft and tighten setscrew.
- i. Reinstall handle retaining nut.
- j. Install side latch plate.
- k. Reinstall latch rod holding plates and latch rods.
- l. Reinstall holding plate retaining nut.

8-16.3 Replace Door Hinge (Piano Hinge).

MOS: 83FJ6, Reproduction Equipment Repairer

TOOLS: 1/4 in. Electric Drill
5/32 in. Drill Bit
Pop Rivet Gun

SUPPLIES: Storage Cabinet Hinge
5/32 in. Pop Rivets
8-32 x 1/2 in. Screws (4 required)
8-32 Nuts (4 required)

- a. Drill out rivets holding hinge to cabinet and remove hinge.
- b. Install new hinge and temporarily secure with four screws and nuts.
- c. Close and latch cabinet door and install pop rivets.
- d. Remove temporarily installed screws and nuts, and install pop rivets.

8-16.4 Replace Latch (Flush Type).

MOS: 83FJ6, Reproduction Equipment Repairer

TOOLS: 7/8 in. Combination Wrench
9/16 in. Combination Wrench
3/16 in. Nut Driver

SUPPLIES: Flush Type Latch

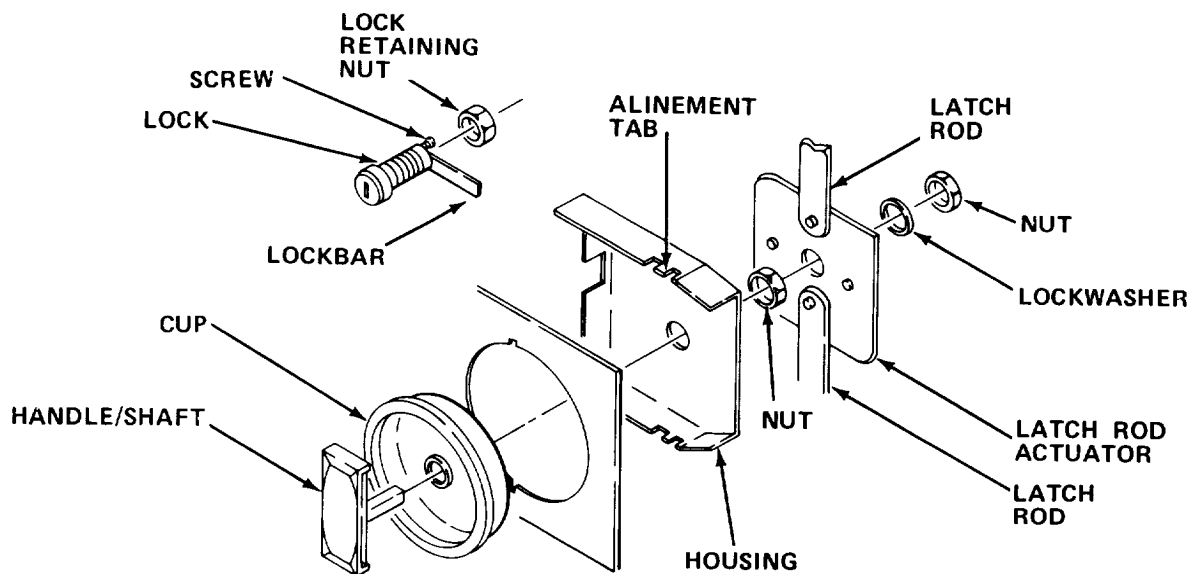

- a. Remove nut and lockwashers from shaft.

- b. Remove latch rod actuator and two latch rods.
- c. Remove screw and lockbar.
- d. Remove nut and housing.
- e. Remove handle/shaft and cup.
- f. Remove lock retaining nut and lock.
- g. Install new lock and attach to door with lock retaining nut.
- h. Install new cup and handle/shaft with handle in closed position.

NOTE

Check that alignment tabs on housing are inserted in notches cut in door.

- i. Attach housing, fingertight, with nut.
- j. Install lockbar and secure with screw.
- k. Insert latch rods into guides located at top and bottom of door.
- l. Install latch rod actuator on shaft with pins facing front of door and guide latch rod ends on upper and lower actuator pins.
- m. Secure latch rod actuator against housing with lockwasher and nut.

8-16.5 Replace Hinge.

MOS: 83FJ6, Reproduction Equipment Repairer

TOOLS: Flat Tip Screwdriver

SUPPLIES: Hinge

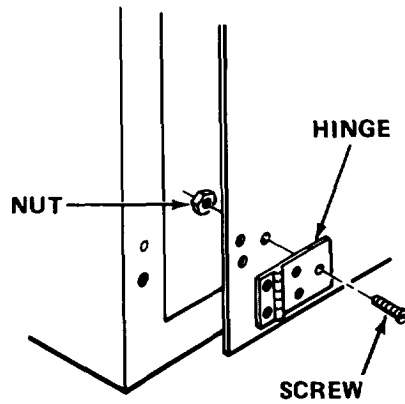

- a. Remove nuts and screws which attach hinge to frame and door.
- b. Remove hinge.
- c. Set new hinge in position and attach to frame and door with screws and nuts.

8-16.6 Replace Leg Support(s).

MOS: 83FJ6, Reproduction Equipment Repairer

TOOLS: Flat Tip Screwdriver
Cross Tip Screwdriver

SUPPLIES: Right Leg Support
Left Leg Support

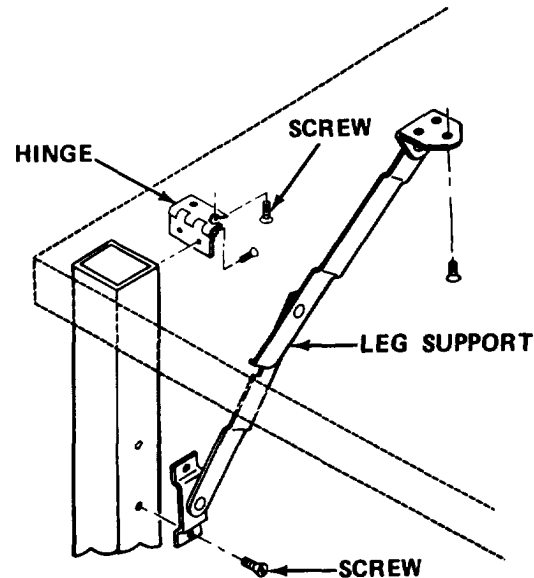

- a. Remove screws holding leg support.
- b. Remove screws holding leg hinge.
- c. Replace hinge, align holes and install screws. Tighten firmly.

NOTE

Leg supports are for right or left sides. Supports are not interchangeable.

- d. Replace leg support, align holes, and replace screws. Tighten firmly.
- e. Move table to stored position. Check for free movement of hinges and leg supports. Lock legs. Surface should not wobble.

8-16.7 Remove/Install Corkboard.

MOS: 83FJ6, Reproduction Equipment Repairer

TOOLS: Cross Tip Screwdriver

SUPPLIES: Corkboard

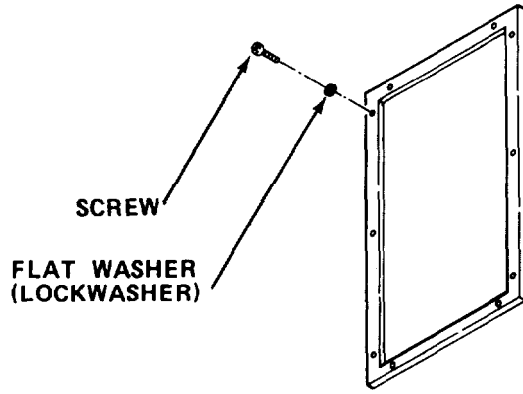

- a. Remove attaching hardware securing defective corkboard to wall.
- b. Remove defective corkboard.
- c. Position new corkboard and align mounting holes.
- d. Secure new corkboard to wall with attaching hardware.

8-16.8 Remove/Install Bindery Table.

MOS: 83FJ6, Reproduction Equipment Repairer

TOOLS: 1/2 in. Drive Socket Set

SUPPLIES: Bindery Table

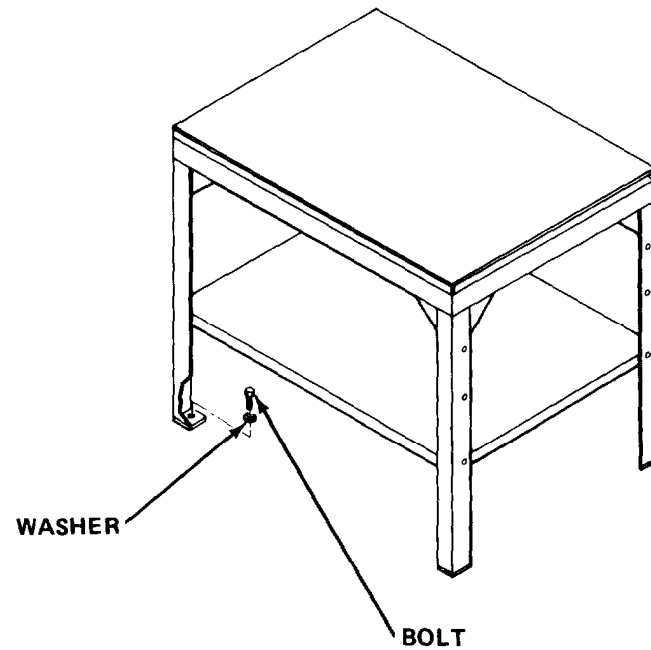

- a. Remove bolts and washers securing defective table to floor.
- b. Remove defective table.
- c. Align legs of, new table with holes in floor.
- d. Secure new table to floor with bolts and washers.

8-16.9 Remove/Install Folding Table.

MOS: 83FJ6, Reproduction Equipment Repairer

TOOLS: Cross Tip Screwdriver

SUPPLIES: Folding Table

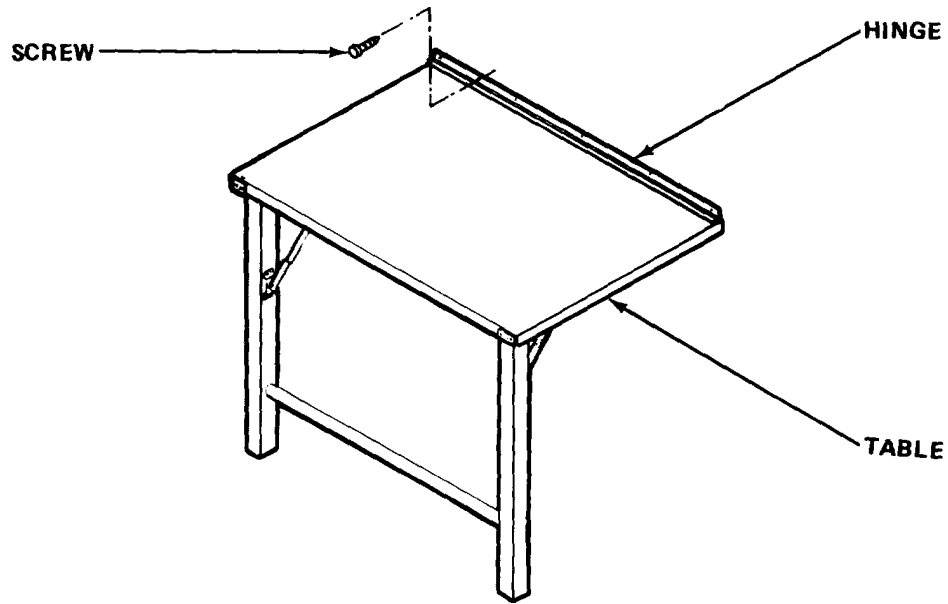

- a. Remove screws from hinge securing defective table to wall.
- b. Remove defective table from section.
- c. Align holes in hinge on new table with mounting holes on wall.
- d. Secure new table to wall with screws.

8-16.10 Remove/Install Five Drawer Photolithographic Cabinet.

MOS: 83FJ6, Reproduction Equipment Repairer

TOOLS: 1/2 in. Drive Socket Set

SUPPLIES: Five Drawer Photolithographic Cabinet

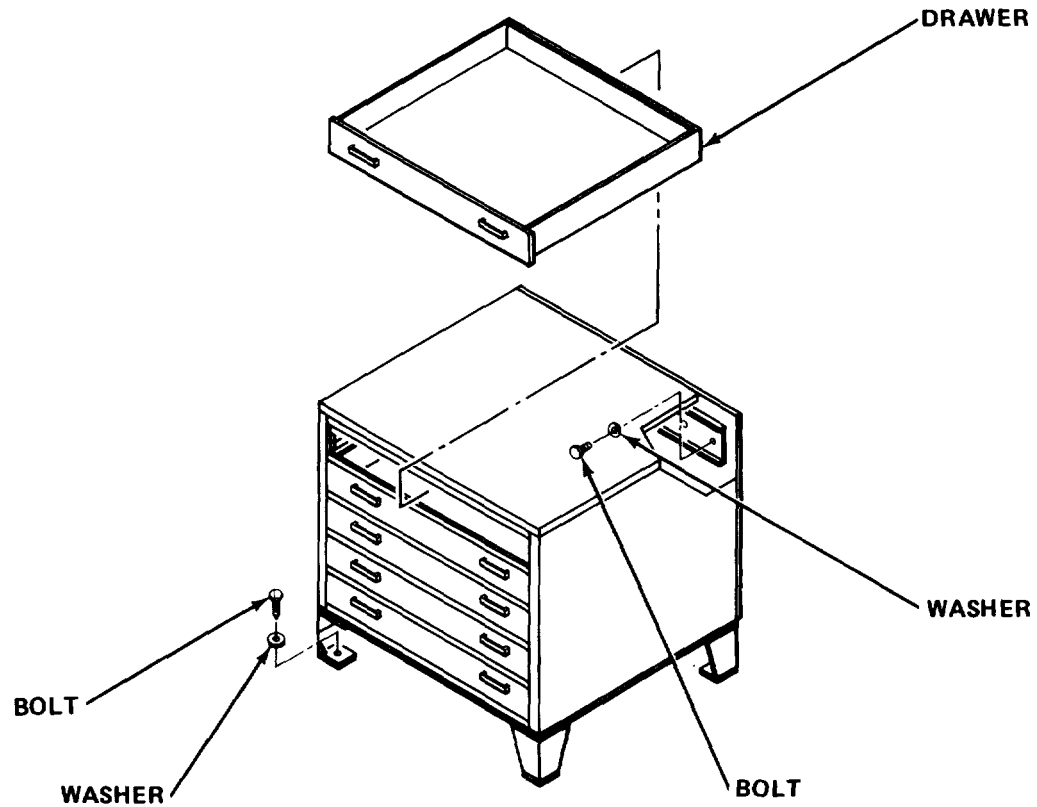

- a. Remove drawers.
- b. Remove bolts and washers holding defective cabinet to wall.
- c. Remove bolts and washers holding defective cabinet to floor.
- d. Remove defective cabinet.
- e. Remove drawers from new cabinet.
- f. Align new cabinet legs over holes in floor and install bolts and washers.
- g. Install bolts and washers holding new cabinet to wall.
- h. Install drawers in new cabinet.

8-16.11 Remove/Install One Drawer Photolithographic Cabinet.

MOS: 83FJ6, Reproduction Equipment Repairer

TOOLS: 1/2 in. Drive Socket Set

SUPPLIES: One Drawer Photolithographic Cabinet

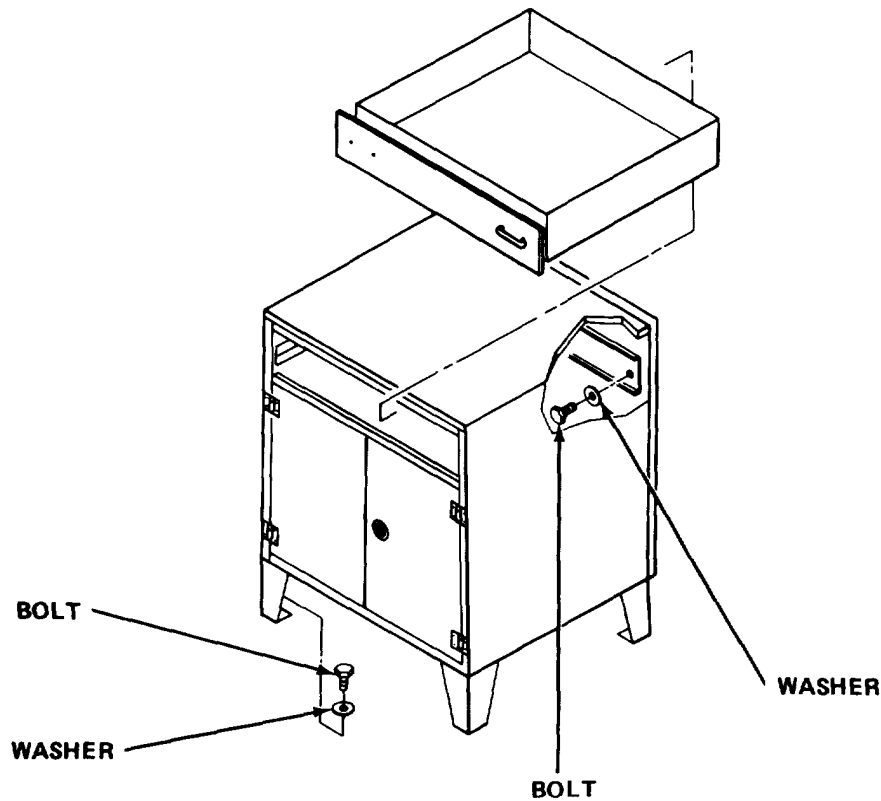

- a. Open doors and remove drawer.
- b. Remove bolts and washers holding defective cabinet to wall.
- c. Remove bolts and washers holding defective cabinet to floor.
- d. Remove defective cabinet.
- e. Remove drawer of new cabinet.
- f. Align new cabinet legs over holes in floor and install bolts and washers.
- g. Install bolts and washers holding new cabinet to wall.
- h. Install drawer and close door.

8-17. PREPARATION FOR STORAGE OR SHIPMENT. Contact your battalion for packing and shipping instructions.

Section V DIRECT/GENERAL SUPPORT MAINTENANCE

There are no direct/general support maintenance procedures assigned for this equipment.

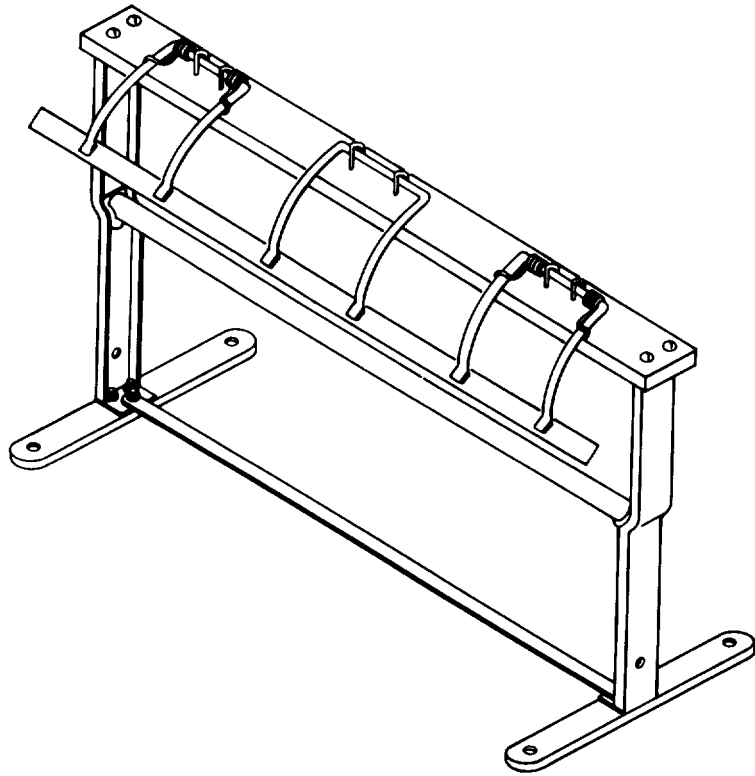

CHAPTER 9 SUPPORT ITEMS

Section I INTRODUCTION

9-1. GENERAL INFORMATION.

9-1.1 Scope. This chapter covers the support items contained in this section. The support item consists of the wrapping paper holder and cutter.

9-2. EQUIPMENT DESCRIPTION.

9-2.1 Equipment Characteristics, Capabilities, and Features.

Wrapping paper holder and cutter. Holds and cuts up to 36 in. wide rolled paper.

9-3. TECHNICAL PRINCIPLES OF OPERATION. There are no technical principles of operation for this equipment.

Section II OPERATING INSTRUCTIONS

9-4. DESCRIPTION AND USE OF OPERATOR'S CONTROLS AND INDICATORS. There are no operator's controls and indicators for this equipment.

9-5. OPERATOR PREVENTIVE MAINTENANCE CHECKS AND SERVICES.

a. Before You Operate. Always keep in mind the WARNINGS and CAUTIONS. Perform your before (B) PMCS.

b. While You Operate. Always keep in mind the WARNINGS and CAUTIONS. Perform your during (D) PMCS.

c. After You Operate. Be sure to perform your after (A) PMCS.

d. If Your Equipment Fails To Operate. Troubleshoot with proper equipment. Report any deficiencies using the proper forms. See DA Pam 738-750.

9-5.1 PMCS Procedures.

- a. PMCS are designed to keep the equipment in good working condition by performing periodic service tasks.
- b. Service intervals provide you, the operator, with time schedules that determine when to perform specified service tasks.
- c. The "Equipment is Not Ready/Available If" column is used for identification of conditions that make the equipment not ready/available for readiness reporting purposes or denies use of the equipment until corrective maintenance is performed.
- d. If your equipment fails to operate after PMCS is performed, immediately report this condition to your supervisor.
- e. Perform weekly as well as before operation if you are the assigned operator and have not operated the item since the last weekly or if you are operating the item for the first time.
- f. Item number column. Item numbers are assigned in chronological ascending sequence regardless of interval decimation. These numbers are used for your "TM Number" column on DA Form 2404, Equipment Inspection and Maintenance Worksheet in recording results of PMCS.
- g. Interval columns. This column determines the time period designated to perform your PMCS.
- h. Item to be inspected and procedures column. This column lists functional groups and their respective assemblies and subassemblies as shown in the Maintenance Allocation Chart (Appendix B). The appropriate check or service procedure follows the specific item to be inspected.
- i. Equipment is not ready/available if: column. This column indicates the reason or cause why your equipment is not ready/available to perform its primary mission.

Table 9-1. OPERATOR PREVENTIVE MAINTENANCE CHECKS AND SERVICES

NOTE

If the equipment must be kept in continuous operation, check and service only those items that can be checked and serviced without disturbing operation. Make the complete checks and services when the equipment can be shut down.

		B - Before D - During A - After	W - Weekly M - Monthly Q - Quarterly	AN - Annually S - Semiannually BI - Biennially	(Number) - Hundreds of Hours	
ITEM NO.	INTERVAL	ITEM TO BE INSPECTED			PROCEDURE	For Readiness Reporting, Equipment Is Not Ready/ Available If:
1	Q	<u>SUPPORT ITEMS</u> <u>Inspect Wrapping Paper Holder and Cutter.</u> Inspect blade for nicks and burrs.				

9-6. OPERATION UNDER USUAL CONDITIONS.

9-6.1 Assembly and Preparation for Use.

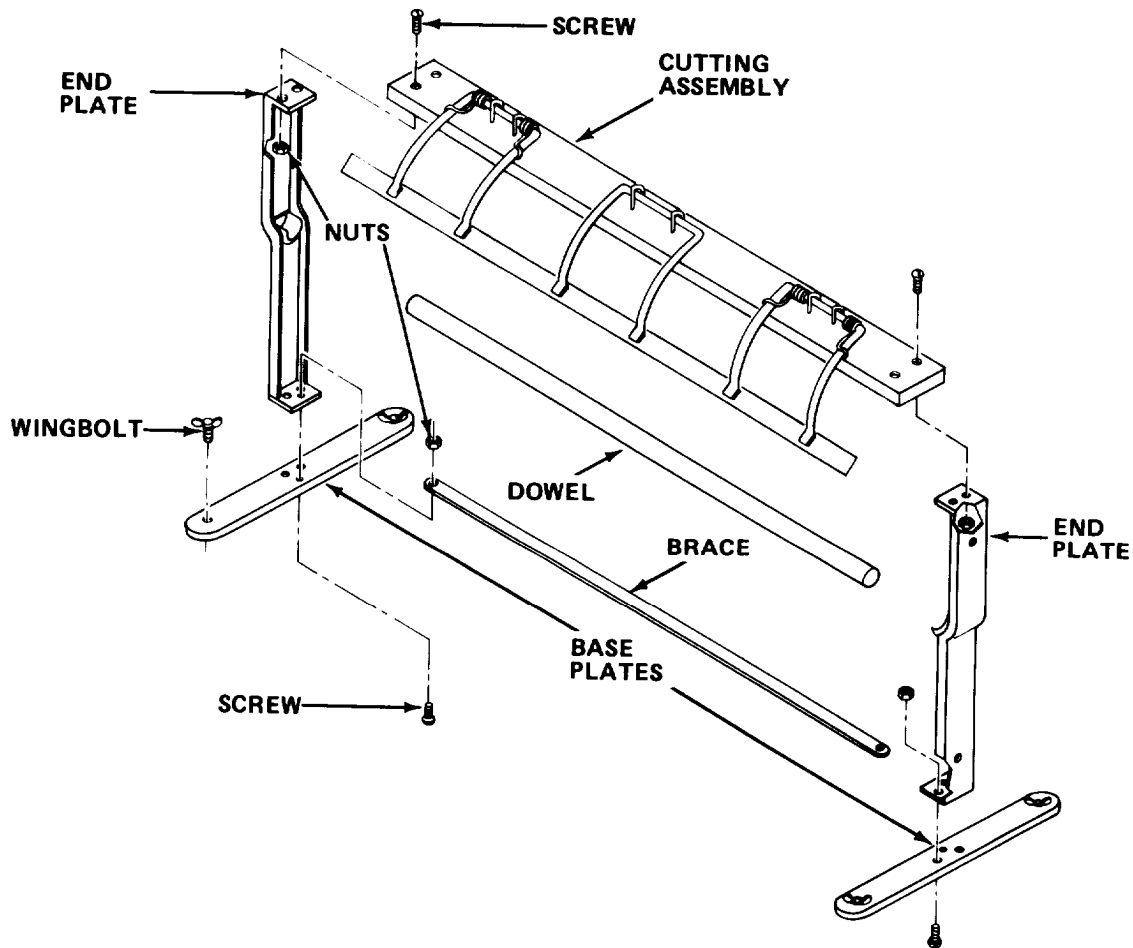

- a. Attach end plates to cutting assembly with screws and nuts.
- b. Attach base plates to end plates with screws and nuts.
- c. Attach brace to end plates with screws and nuts.
- d. Attach assembled wrapping paper holder and cutter to folding table with wingbolts.
- e. Insert dowel through center of paper roll and place in assembled wrapping paper holder and cutter.

9-7. OPERATION UNDER UNUSUAL CONDITIONS. This equipment is designed for operation only in a controlled environment.

Section III OPERATOR MAINTENANCE

- 9-8. LUBRICATION INSTRUCTIONS. This equipment does not require lubrication.
- 9-9. TROUBLESHOOTING PROCEDURES. There are no operator troubleshooting procedures assigned for this equipment.
- 9-10. MAINTENANCE PROCEDURES. There are no operator maintenance procedures assigned for this equipment.

Section IV ORGANIZATIONAL MAINTENANCE

- 9-11. LUBRICATION INSTRUCTIONS. This equipment does not require lubrication.
- 9-12. REPAIR PARTS, SPECIAL TOOLS; TEST, MEASUREMENT, AND DIAGNOSTIC EQUIPMENT (TMDE); AND SUPPORT EQUIPMENT. These items are not required at this level of maintenance.
- 9-13. SERVICE UPON RECEIPT.
- 9-13.1 Checking Unpacked Equipment.
- a. Inspect the equipment for damage incurred during shipment. If equipment has been damaged, report the damage on DD Form 6, Packing Improvement Report.
 - b. Check the equipment against the packing list to see if the shipment is complete. Report all discrepancies in accordance with the instructions of DA Pam 738-750.
 - c. Check to see whether the equipment has been modified.
- 9-14. ORGANIZATIONAL PREVENTIVE MAINTENANCE CHECKS AND SERVICES. There are no organizational PMCS procedures assigned for this equipment,
- 9-15. ORGANIZATIONAL TROUBLESHOOTING PROCEDURES. There are no organizational troubleshooting procedures assigned for this equipment.
- 9-16. MAINTENANCE PROCEDURES. There are no organizational maintenance procedures assigned for this equipment.

9-17. PREPARATION FOR STORAGE OR SHIPMENT. Contact your battalion for packing and shipping instructions.

Section V DIRECT/GENERAL SUPPORT MAINTENANCE

There are no direct/general support maintenance procedures assigned for this equipment.

APPENDIX A

REFERENCES

A-1. SCOPE.

This appendix lists all forms, field manuals, technical manuals and miscellaneous publications referenced in this manual.

A-2. FORMS.

Recommended Changes to Publications and Blank Forms	DA Form 2028
Recommended Changes to Equipment Technical Publications	DA Form 2028-2
Equipment Inspection and Maintenance Worksheet	DA Form 2404
The Army Maintenance Management System (TAMMS).	DA Pam 738-750
Quality Deficiency Report	SF 368

A-3. FIELD MANUALS.

Camouflage.	FM 5-20
First Aid for Soldiers.	FM 21-11
Nuclear, Biological and Chemical (NBC) Defense (Reprinted w/Basic Incl C1)	FM 21-40
Basic Cold Weather Manual	FM 31-70
Northern Operations	FM 31-71
Metal Body Repair and Related Operations	FM 43-2

A-4. TECHNICAL MANUALS.

Administrative Storage of Equipment	TM 740-90-1
Chemical, Biological and Radiological (CBR) Decontamination	TM 3-220
Operator, Organizational, Direct Support and General Support Maintenance Manual: Air Conditioner, Horizontal, Compact, 208-Volt, 3-Phase, 18,000 Btu Cooling, 12,000 Btu Heating.	TM 5-4120-367-14

Operator, Organizational, Direct Support and
General Support Maintenance Manual for Chassis,
Semi-Trailer, Container Transporter (ADCOR) TM 5-2330-305-14

Organizational, Direct Support and General Support
Maintenance Repair Parts and Special Tools List
(Including Depot Maintenance Repair Parts and
Special Tools) for Air Conditioner/Heater TM 5-4120-367-24p

Organizational, Direct Support and General Support
Maintenance Repair Parts and Special Tools List
(Including Depot Maintenance Repair Parts and
Special Tools) for Chassis, Semi-Trailer,
Container Transporter (ADCOR) TM 5-2330-305-24p

Organizational, Direct Support and General Support
Maintenance Repair Parts and Special Tools List
(RPSTL) (Including Depot Maintenance Repair Parts
and Special Tools) for Finishing Section. TM 5-3610-253-24p

Painting Instructions for Field Use TM 43-0139

Procedure for the Destruction of Equipment to
Prevent Enemy Use TM 750-244-3

Use and Care of Hand Tools and Measuring Tools TM 9-243

A-5. MISCELLANEOUS PUBLICATIONS.

Lubrication Order: Topographic Support System
Finishing Section, Model ADC-TSS-16 LO 5-3610-253-12

Lubrication Order: Topographic Support
System Chassis, Semi-Trailer, Container
Transporter (ADCOR). LO 5-2330-305-12

APPENDIX B**MAINTENANCE ALLOCATION CHART (MAC)**

INTRODUCTION**The Army Maintenance System MAC**

This introduction provides a general explanation of all maintenance and repair functions authorized at the two maintenance levels under the Two-Level Maintenance System concept.

This MAC (immediately following the introduction) designates overall authority and responsibility for the performance of maintenance functions on the identified end item or component. The application of the maintenance functions to the end item or component levels, which are shown on the MAC in column (4) as:

Field – includes two columns, Unit maintenance and Direct Support maintenance. The Unit maintenance column is divided again into two more subcolumns, C for Operator or Crew and O for Unit maintenance.

Sustainment – includes two subcolumns, General Support (H) and Depot (D)

The tools and test equipment requirements (immediately following the MAC) list the tools and test equipment (both special tools and common tool sets) required for each maintenance function as referenced from the MAC.

The remarks (immediately following the tools and test equipment requirements) contain supplemental instructions and explanatory notes for a particular maintenance function.

Maintenance Functions

Maintenance functions are limited to and defined as follows:

1. Inspect. To determine the serviceability of an item by comparing its physical, mechanical, and/or electrical characteristics with established standards through examination (e.g., by sight, sound, or feel). This includes scheduled inspection and gagings and evaluation of cannon tubes.
2. Test. To verify serviceability by measuring the mechanical, pneumatic, hydraulic, or electrical characteristics of an item and comparing those characteristics with prescribed standards on a scheduled basis, i.e., load testing of lift devices and hydrostatic testing of pressure hoses.
3. Service. Operations required periodically to keep an item in proper operating condition; e.g., to clean (includes decontaminate, when required), to preserve, to drain, to paint, or to replenish fuel, lubricants, chemical fluids, or gases. This includes scheduled exercising and purging of recoil mechanisms. The following are examples of service functions:
 - a. Unpack. To remove from packing box for service or when required for the performance of maintenance operations.
 - b. Repack. To return item to packing box after service and other maintenance operations.
 - c. Clean. To rid the item of contamination.

- d. Touch up. To spot paint scratched or blistered surfaces.
- e. Mark. To restore obliterated identification.
- 4. Adjust. To maintain or regulate, within prescribed limits, by bringing into proper position, or by setting the operating characteristics to specified parameters.
- 5. Align. To adjust specified variable elements of an item to bring about optimum or desired performance.
- 6. Calibrate. To determine and cause corrections to be made or to be adjusted on instruments of test, measuring, and diagnostic equipment used in precision measurement. Consists of comparisons of two instruments, one of which is a certified standard of known accuracy, to detect and adjust any discrepancy in the accuracy of the instrument being compared.
- 7. Remove/Install. To remove and install the same item when required to perform service or other maintenance functions. Install may be the act of emplacing, seating, or fixing into position a spare, repair part, or module (component or assembly) in a manner to allow the proper functioning of an equipment or system.
- 8. Paint. To prepare and spray color coats of paint so that the ammunition can be identified and protected. The color indicating primary use is applied, preferably, to the entire exterior surface as the background color of the item. Other markings are to be repainted as original so as to retain proper ammunition identification.
- 9. Replace. To remove an unserviceable item and install a serviceable counterpart in its place. "Replace" is authorized by the MAC and assigned maintenance level is shown as the third position code of the Source, Maintenance and Recoverability (SMR) code.
- 10. Repair. The application of maintenance services, including fault location/troubleshooting, removal/installation, disassembly/assembly procedures, and maintenance actions to identify troubles and restore serviceability to an item by correcting specific damage, fault, malfunction, or failure in a part, subassembly, module (component or assembly), end item, or system.

NOTE

The following definitions are applicable to the "repair" maintenance function:
Services. Inspect, test, service, adjust, align, calibrate, and/or replace.

Fault location/troubleshooting. The process of investigating and detecting the cause of equipment malfunctioning; the act of isolating a fault within a system or Unit Under Test (UUT).

Disassembly/assembly. The step-by-step breakdown (taking apart) of a spare/functional group coded item to the level of its least component, and that is assigned an SMR code for the level of maintenance under consideration (i.e., identified as maintenance significant).

Actions. Welding, grinding, riveting, straightening, facing, machining, and/or resurfacing.

- 11. Overhaul. That maintenance effort (service/action) prescribed to restore an item to a completely serviceable/operational condition as required by maintenance standards in appropriate technical publications. Overhaul is normally the highest degree of maintenance performed by the Army. Overhaul does not normally return an item to like new condition.

12. **Rebuild.** Consists of those services/actions necessary for the restoration of unserviceable equipment to a like new condition in accordance with original manufacturing standards. Rebuild is the highest degree of materiel maintenance applied to Army equipment. The rebuild operation includes the act of returning to zero those age measurements (e.g., hours/miles) considered in classifying Army equipment/components.

Explanation of Columns in the MAC

Column (1) Group Number. Column (1) lists FGC numbers, the purpose of which is to identify maintenance significant components, assemblies, subassemblies, and modules with the Next Higher Assembly (NHA).

Column (2) Component/Assembly. Column (2) contains the item names of components, assemblies, subassemblies, and modules for which maintenance is authorized. Column (3) Maintenance Function.

Column (3) lists the functions to be performed on the item listed in column (2). (For a detailed explanation of these functions refer to "Maintenance Functions" outlined above). Column (4) Maintenance Level.

Column (4) specifies each level of maintenance authorized to perform each function listed in column (3), by indicating work time required (expressed as manhours in whole hours or decimals) in the appropriate subcolumn. This work time figure represents the active time required to perform that maintenance function at the indicated level of maintenance. If the number or complexity of the tasks within the listed maintenance function varies at different maintenance levels, appropriate work time figures are to be shown for each level. The work time figure represents the average time required to restore an item (assembly, subassembly, component, module, end item, or system) to a serviceable condition under typical field operating conditions. This time includes preparation time (including any necessary disassembly/assembly time), troubleshooting/fault location time, and quality assurance time in addition to the time required to perform the specific tasks identified for the maintenance functions authorized in the MAC. The symbol designations for the various maintenance levels are as follows:

Field: C Operator or Crew maintenance
O Unit maintenance
F Direct Support maintenance

Sustainment:

L Specialized Repair Activity
H General Support maintenance
D Depot maintenance

NOTE

The "L" maintenance level is not included in column (4) of the MAC. Functions to this level of maintenance are identified by work time figure in the "H" column of column (4), and an associated reference code is used in the REMARKS column (6). This code is keyed to the remarks and the SRA complete repair application is explained there.

Column (5) Tools and Equipment Reference Code. Column (5) specifies, by code, those common tool sets (not individual tools), common Test, Measurement and Diagnostic Equipment (TMDE), and special tools, special TMDE and special support equipment required to perform the designated function. Codes are keyed to the entries in the tools and test equipment table.

Column (6) Remarks Code. When applicable, this column contains a letter code, in alphabetical order, which is keyed to the remarks table entries.

Table 1. MAC for Finishing Section

(1) GROUP NUMBER	(2) COMPONENT/ ASSEMBLY	(3) MAINT- ENANCE FUNCTION	(4) MAINTENANCE LEVEL				(5) TOOLS AND EQUIPMENT REF CODE	(6) REMARKS CODE	
			FIELD		SUSTAINMENT				
			UNIT		DIRECT SUPPORT	GENERAL SUPPORT			DEPOT
			C	O	F	H			D
00	Finishing Section	Overhaul					**		
01	Van Body	Inspect	0.8						
		Service	0.9	0.5				9, 13, 15, 19	
		Repair		1.0	1.5		2.0	1, 3, 6, 21	C
	Fluorescent Light Assy	Repair	0.1	0.7				1	
	Blackout/Dome Light Assy	Repair	0.2					1	
	Exhaust Fan Assy	Repair		0.5				1	C
	Air Conditioner/Heater Assy	Replace					2.0	1	B
	Electrical Assembly	Inspect	0.5					3	
		Repair	0.9		1.0			1, 3	
	Telephone Binding Post Assy	Repair		0.7				1	
	Emergency Light Assy	Replace		0.3				1	
	Tiedown Socket Assy	Replace		0.3				6	
	Level Indicator Assy	Repair		0.6				2, 3	
	Blackout Curtain Assy	Repair		1.0				6	
	Personnel Ladder Assy	Repair		0.8				6, 21	C
	Personnel/Cargo Door Assy	Replace			1.5			4	
		Repair			2.0			4	
** Depot personnel will determine work times.									

Table 1. MAC for
Finishing Section
(Continued)

(1) GROUP NUMBER	(2) COMPONENT/ ASSEMBLY	(3) MAINT- ENANCE FUNCTION	(4) MAINTENANCE LEVEL				(5) TOOLS AND EQUIPMENT REF CODE	(6) REMARKS CODE	
			FIELD		SUSTAINMENT				
			UNIT		DIRECT SUPPORT	GENERAL SUPPORT			DEPOT
			C	O	F	H			D
02	Paper Drilling Machine	Inspect	0.2						
		Service	0.3					7	
		Remove/ Install	0.3					6	
		Repair	1.3					1, 4, 5	C
02	Drilling Assembly	Inspect	0.2						
		Repair	0.5					4	C
		Power Cord Assembly	Replace	0.3				1	
02	Motor Assembly	Replace	0.3				1, 3		
03	Paper Stitcher	Inspect	0.2					12, 13	
		Service	0.3					10	
		Adjust	0.2	0.3				4, 11, 13, 16	C
		Remove/ Install	0.3					6	
	Repair	0.8	1.3				4, 11, 12, 13	C	
	Electrical Assembly	Repair	0.3					1, 4	C
	Cutter Assembly	Repair	0.3					12, 13	
	Driver Assembly	Repair	0.3					12, 13	
	Driver Bar Latch Assembly	Replace	0.3					4	C
	Clutch Spring Assembly	Replace	0.3					1	
03	Motor Assembly	Replace	0.3				4	C	
03	Belt Assembly	Replace	0.3				4	C	

Table 1. MAC for
Finishing Section
(Continued)

(1) GROUP NUMBER	(2) COMPONENT/ ASSEMBLY	(3) MAINT- ENANCE FUNCTION	(4) MAINTENANCE LEVEL				(5) TOOLS AND EQUIPMENT REF CODE	(6) REMARKS CODE		
			FIELD		SUSTAINMENT					
			UNIT		DIRECT SUPPORT	GENERAL SUPPORT			DEPOT	
			C	O	F	H			D	
04	Paper Shredder	Inspect	0.2							
		Service	0.3					8, 10		
		Remove/ Install	0.5					3		
		Repair	2.5					1, 3, 24, 33	C	
	Electrical Assembly	Repair	0.8				3, 4	C		
	Motor Assembly	Replace			0.5		1			
	Drive Chain Assembly	Replace			0.3		1			
05	Paper Cutter (Model 92CS)	Inspect	0.3	0.5				**	17, 23	
		Service	0.3	3.0					1, 13, 22	
		Adjust	0.3		1.0				1, 3, 26, 33	
		Replace	1.5						1, 3	
		Repair	0.5	3.8	5.8				1, 3, 6, 13, 14, 18, 23	
		Lighting Assembly	Inspect	0.2						
	Repair		0.3					3, 13, 25		
		Knife Assembly	Adjust	0.2		0.8			3, 23, 31, 32, 35	
	Repair		2.8					3, 25, 29, 30, 35		
		Main Drive Clutch Assembly	Adjust			0.5			3, 26	
	Replace				0.5			1, 3		
	Repair		0.5					3, 23, 31	C	
		Main Drive Gear Assembly	Repair	0.6					3, 23	C
		Main Drive Motor Assembly	Repair	0.5					3	
	Connecting Rod Assembly	Replace					0.5	1, 3, 30		
Repair		0.3						3, 33	C	
	Carrier Assembly	Adjust	0.3					3, 31		
	Backgauge Assembly	Adjust	0.3					3		
Repair		1.0		0.8				3		
	Motor V-Belt Assembly	Repair	0.3					3		

Table 1. MAC for
Finishing Section
(Continued)

(1) GROUP NUMBER	(2) COMPONENT/ ASSEMBLY	(3) MAINT- ENANCE FUNCTION	(4) MAINTENANCE LEVEL				(5) TOOLS AND EQUIPMENT REF CODE	(6) REMARKS CODE	
			FIELD		SUSTAINMENT				
			UNIT		DIRECT SUPPORT	GENERAL SUPPORT			DEPOT
			C	O	F	H			D
05A	Drive Motor Assembly	Repair		0.5			3		
	Brake Assembly	Replace			0.5		3, 23	C	
	Optical Measurement Indicator Assembly	Inspect Repair	0.2 0.3				13, 15		
	Hydraulic Assembly	Service Repair			1.0 2.5		1, 3 3		
	Pump Assembly	Replace			0.8		1, 27	C	
	Control Block Assembly	Replace			0.3		24, 27, 34	C	
	Cylinder Assembly	Replace			0.5		1, 3, 24, 27, 35	C	
	Electronic Assembly	Repair			1.3		3		
	Plug-In PC Card	Replace			0.1		3	A	
	Motherboard PC Card	Replace			0.3		3	A	
	Paper Cutter (Model 92SD)	Inspect Service	0.1 0.2	0.1 2.5	1.1 2.4		3, 17, 35 1, 22		
		Adjust		0.7	1.1		1, 3, 5, 20, 23, 26, 31, 35	C	
		Repair Replace Test	0.3	2.2	1.8 9.5 0.6		35 1, 3 3, 20, 36	C	
	Motor Control Assembly	Replace Repair			0.6 2.5		3, 18 1, 33		
	PCB Rack Assembly	Adjust Repair			0.5 1.5		3, 20, 28 3		
	Power Module Assembly	Repair			1.8		3, 33		
	Linear Scale Assembly	Replace			0.5		3		
	Backguage Brake Assembly	Adjust Replace		0.3		1.0	3 3, 33		

Table 1. MAC for
Finishing Section
(Continued)

(1) GROUP NUMBER	(2) COMPONENT/ ASSEMBLY	(3) MAINT- ENANCE FUNCTION	(4) MAINTENANCE LEVEL				(5) TOOLS AND EQUIPMENT REF CODE	(6) REMARKS CODE	
			FIELD		SUSTAINMENT				
			UNIT		DIRECT SUPPORT	GENERAL SUPPORT			DEPOT
			C	O	F	H			D
	Backgauge Sledge Assembly	Inspect Adjust	0.1 0.8				3		
	Main Gear Drive/Clutch Assembly	Inspect Adjust Replace Repair	0.5 0.6	0.3 5.6			3, 23 1, 3 3, 23, 31	C	
	Safety Bolt Assembly	Adjust Replace Repair		0.3		0.6 0.6	2, 23 3 3		
	Connecting Rod Assembly	Adjust Replace Repair	0.3	1.5 0.2			3 1, 3 3		
	Inch Valve Assembly	Adjust Replace Repair		0.3 1.3 0.2			1, 26 3, 27 1, 3		
	Clamp Cylinder Assembly	Replace		3.0			1, 3, 24, 27		
06	Shrink Wrap System	Inspect Service	0.1 0.2						
07	Mason-type Psychrometer	Inspect Service	0.1 0.2 0.1 0.1						
08	Furniture and Cabinets	Inspect Remove/ Install Replace	0.3 1.5 1.0				3 1, 3, 21	C	
09	Support Items	Inspect	0.3						

**Table 2. Tool and Test Equipment
for Finishing Section**

Tool or Test Equipment	Maintenance Level	Nomenclature	National Stock Number	Tool Number
1	O	Shop Equipment, Automotive Maint and Repair, Common # 1 Plus Metric Option	4910-00-754-0654	
2	O	Tool Kit, Carpenters Eng. Squad	5180-00-293-2875	
3	O	Tool Kit, General Mechanic's Automotive Plus Metric Option	5180-00-177-7033	
4	O, F, D	Tool Kit, Electronic Equipment	5180-00-605-0079	
5	F, D	Tool Kit, Electronic Equipment	5180-00-610-8177	
6	O, F, D	Tool Kit, Light Machine Repair	5180-00-596-1540	
7	C	Goggles, Safety	4240-00-052-3776	
8	C	Brush, Lens	5920-00-205-0565	
9	C	Brush, Wire	7920-00-291-5815	
10	C	Hand Oiler	4930-00-277-1547	
11	C	Needle Nose Pliers	5120-00-268-3579	
12	C	Screwdriver, Cross Tip No. 2	5120-00-234-8913	
13	C	Screwdriver, Flat Tip	5120-00-222-8852	
14	C	Soft Face Hammer	5120-00-596-1071	
15	C	Wrench, Adjustable	5120-00-264-3795	
16	C	Wrench, Combination, 3/4 Inch	5120-00-228-9510	
17	C	T-Handle, Key		(C0347) 92/40.00.014555
18	O	Heat Shrink Gun		(59164) EP-7
19	O	Spring Scale	6670-00-238-9777	
20	O, F, D	Multimeter		(28480) 3435A

**Table 2. Tool and Test Equipment
for Finishing Section**

Tool or Test Equipment	Maintenance Level	Nomenclature	National Stock Number	Tool Number
21	O, F, D	Rivet Gun	5120-00-017-2849	
22	C	Face Shield, Industrial	4240-00-439-3450	
23	F, D	Feeler Gage, Metric		(93389) 00MM25
24	F, D	Hex Bit Set, Metric		(93389) 4900M
25	C	Key Set, Socket Head Screw 2 mm to 19 mm	5120-01-046-5079	
26	F, D	Manometer, 0-200 BAR		(9C628) 010929
27	F, D	Pump, Hand, Multi-Purpose		(25795) 2P138
28	F, D	Metric Calipers	5120-00-532-8050	
29	O, F, D	Gauge Knife Setting		(C0347) 92/40.00.013746
30	O, F, D	36/41 mm Double Open End Wrench		(C0347) 92/40.00.205375
31	O, F, D	Handles, Knife Reset		(C0347) 92/40.00.010958
32	O, F, D	Wrench, Comb (46 mm)		(93389) 1246M
33	F, D	Tool Kit, Metric		-97403 13225E5083
34	F, D	Tool Kit, Electronic Equipment	5180-00-654-5178	
35	O	Handles, Knife Carrying		(C0347) 92/40.00.206579
36	F, D	Extender Card		(C0347) 92/40.00.019219

**Table 3. Remarks for
Finishing Section**

REFERENCE CODE	REMARKS
A	<p>Replacement of printed circuit boards authorized by the MAC are those identified as damaged, or otherwise defective which:</p> <ul style="list-style-type: none"> a) Can be readily removed/installed with easy-to-use tools b) Do not require critical adjustment, calibration, or alinement before or after installation.
B	<p>See TM 9-4120-367-14 for maintenance procedures.</p>
C	<p>Maintenance personnel and TSS Section 7 maintenance van (which carries the required tools) are authorized by HHC TOE 05336 H600.</p>

APPENDIX C

COMPONENTS OF END ITEM AND BASIC ISSUE ITEMS LISTS

Section I INTRODUCTION

C-1. SCOPE.

This appendix lists components of end item and basic issue items for the Finishing Section to help you inventory items required for safe and efficient operation.

C-2. GENERAL.

The Components of End Item and Basic Issue Items Lists are divided into the following sections:

a. *Section II: Components of End Item.* This listing is for informational purposes only, and is not authority to requisition replacements. As part of the end item, these items must be with the end item whenever it is issued or transferred between property accounts. Illustrations are furnished to assist you in identifying the items.

b. *Section III: Basic Issue Items.* These are the minimum essential items required to place the Finishing Section in operation, to operate it, and to perform emergency repairs. BII must be with the Finishing Section during operation and whenever it is transferred between property accounts. The illustrations will assist you with hard-to-identify items. This manual is your authority to request/requisition replacement BII based on TOE/MTOE authorization of the end item.

C-3. EXPLANATION OF COLUMNS.

The following provides an explanation of columns found in the tabular listings:

a. *Column (1): Illustration Number (Illus Number).* This column indicates the number of the illustration in which the item is shown.

b. *Column (2): National Stock Number.* Indicates the National stock number assigned to the item and will be used for requisitioning purposes.

c. *Column (3): Description.* Indicates the Federal item name and, if required, a minimum description to identify and locate the item. The last line for each item indicates the FSCM (in parentheses) followed by the part number.

d. *Column (4): Unit of Measure (U/M).* Indicates the measure used in performing the actual operational/maintenance function. This measure is expressed by a two-character alphabetical abbreviation (e.g., ea, in, pr).

e. *Column (5): Quantity Required (Qty Rqr).* Indicates the quantity of the item authorized to be used with/on the equipment.

Section II COMPONENTS OF END ITEM

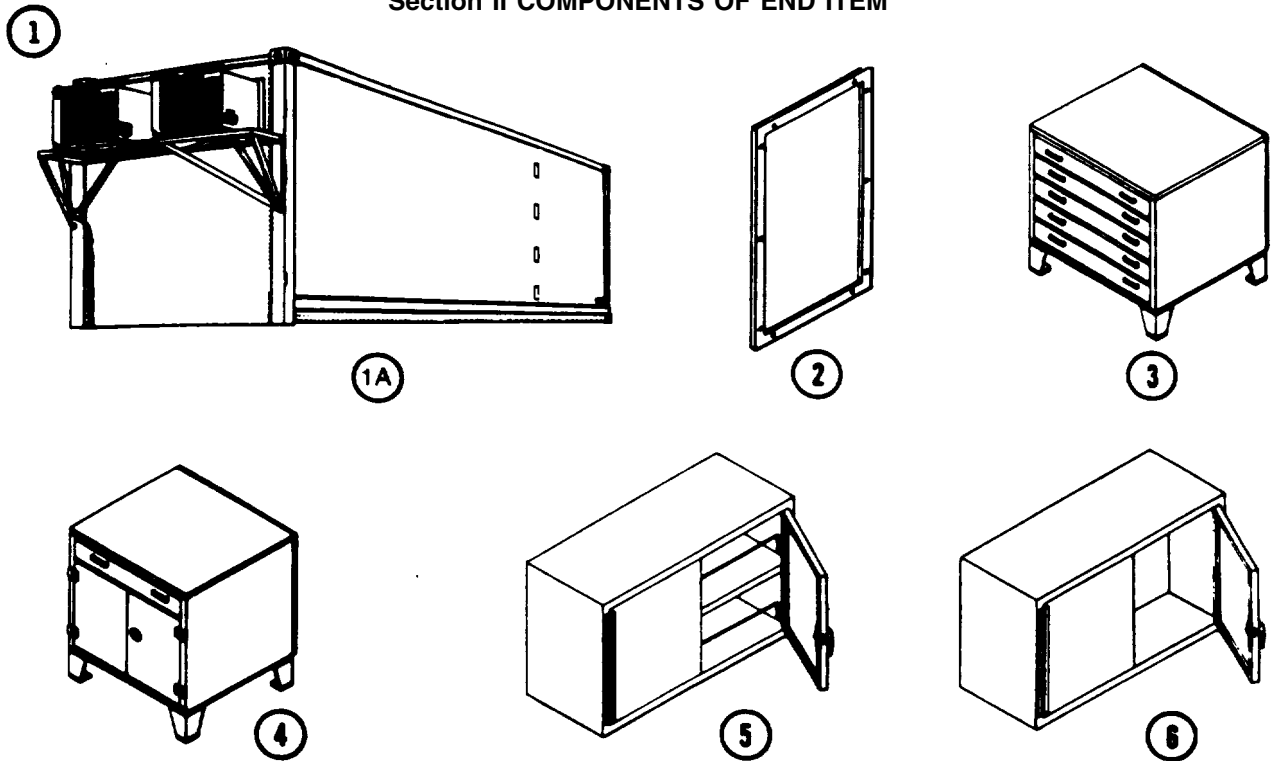

(1) Illus Number	(2) National Stock Number	(3) Description FSCM and Part Number	(4) U/M	(5) Qty Rqr
1	4120-00-974-7206	AIR CONDITIONER (81349) MIL-A-52767	ea	2
1A	3610-01-214-4772	VAN ASSEMBLY - MODIFIED (97403) 13225E3041	ea	1
2	7195-00-105-7941	BULLETIN BOARD: (79B19) T5-2303	ea	1
3		CABINET, STORAGE: PHOTOLITHOGRAPHIC (97403) 13225E4437	ea	
4	7125-00-091-9433	CABINET, STORAGE: PHOTOLITHOGRAPHIC (97403) 13225E4441	ea	1
5	7125-00-286-5259	CABINET, STORAGE: WALL (78252) MIL-C-40060/1, type I	ea	2
6		CABINET, STORAGE: TECH MANUALS (97403) 13225E4648	ea	1

Section II COMPONENTS OF END ITEM - Cont

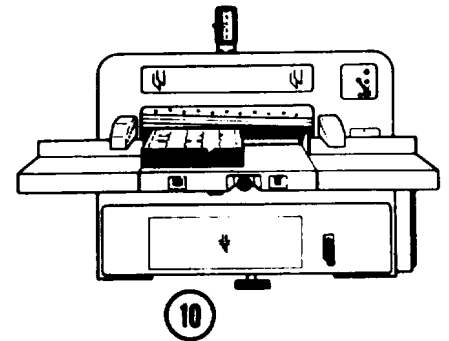
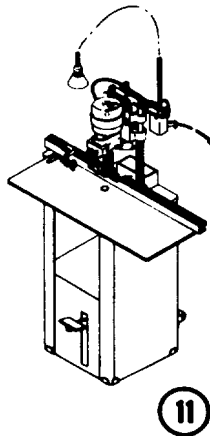
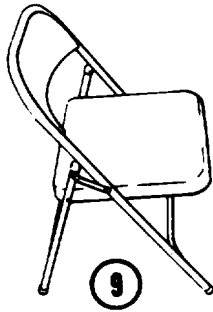
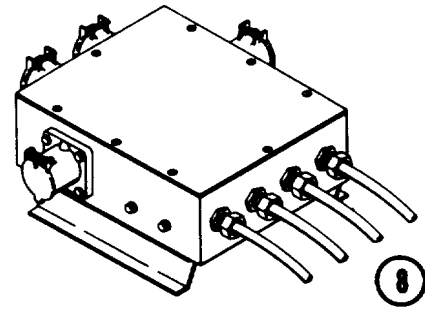
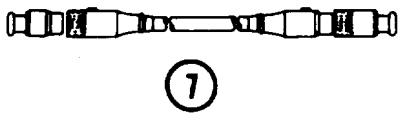

(1) Illus Number	(2) National Stock Number	(3) Description FSCM and Part Number	(4) U/M	(5) Qty Rqr
7	6150-00-134-0847	CABLE ASSEMBLY, POWER ELECTRICAL: (90129) RC1736-5, except 50.5 ft lg	ea	2
8	6150-01-081-9264	CABLE TERMINAL BOX ASSEMBLY, ELECTRICAL, SPECIAL PURPOSE: (51745) TL/TA 1322E6250	ea	1
9	7105-00-269-8463	CHAIR, FOLDING: (80063) 539471	ea	2
10		CUTTER, PAPER, GUILLOTINE: (C0347) Polar Model 92SD or	ea	1
11	3610-00-030-2032	DRILLING MACHINE, PAPER, POWER OPERATED: (11444) style MF or JF	ea	1

Section II COMPONENTS OF END ITEM – Cont

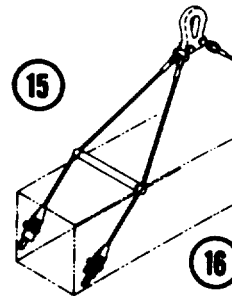
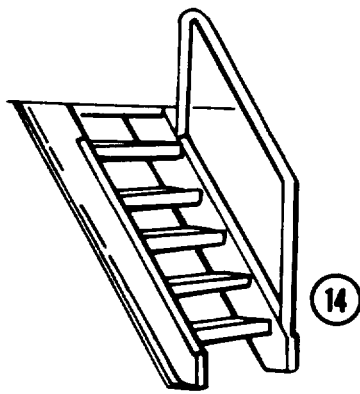
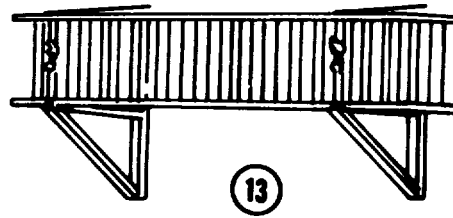
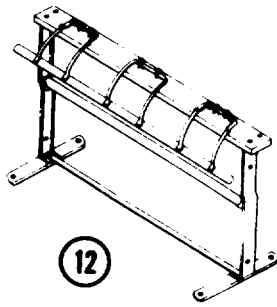

(1) Illus Number	(2) National Stock Number	(3) Description FSCM and Part Number	(4) U/M	(5) Qty Rqr
12	7920-00-298-7040	HOLDER AND CUTTER, WRAPPING PAPER: (81348) FF-H-571, Class A, size 36 in.	ea	1
13	5440-01-152-7757	LADDER, EXTENSION-FOLDING: (39428) 8028T16	ea	1
14	2540-01-133-9726	LADDER, VEHICLE BOARDING: (97403) 13225E3074	ea	2
15		LIFTING AND TIEDOWN DEVICE, TRANSPORTABLE SHELTER: Left hand 1390-4	ea	2
16		LIFTING AND TIEDOWN DEVICE, TRANSPORTABLE SHELTER: Right hand 1390-3	ea	2

Section II COMPONENTS OF END ITEM – Cont

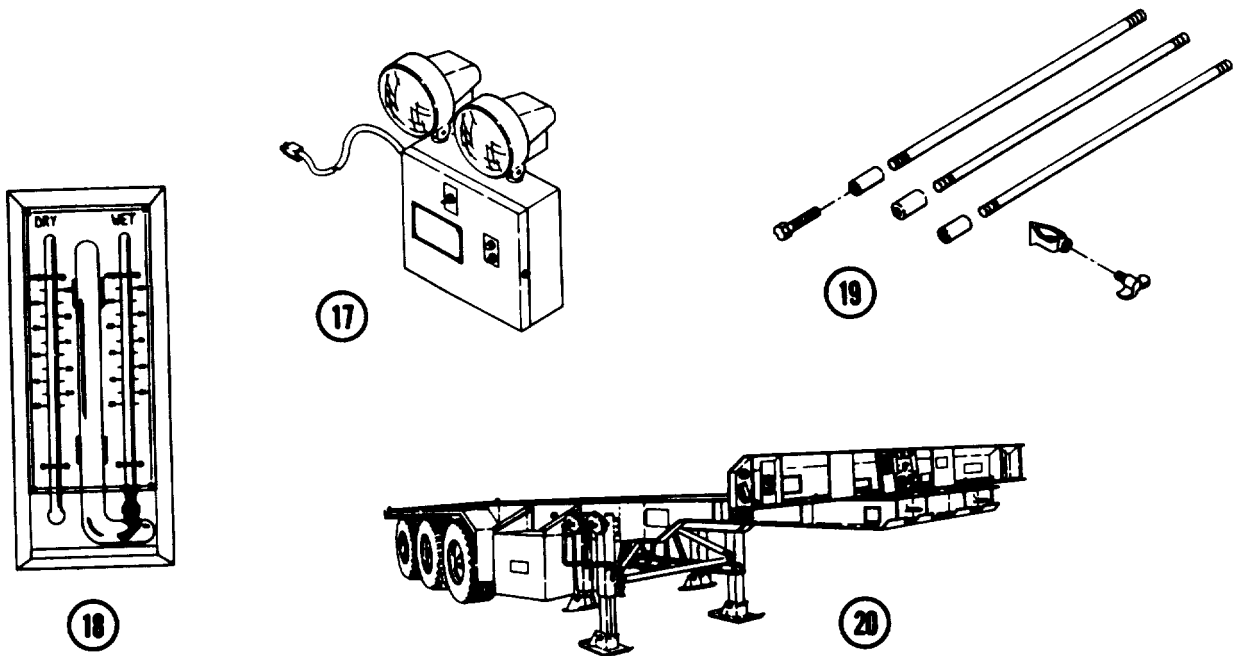

(1) Illus Number	(2) National Stock Number	(3) Description FSCM and Part Number	(4) U/M	(5) Qty Rqr
17		LIGHT, EMERGENCY: (97403) 13225E3396	ea	1
18	6685-00-641-3580	PSYCHROMETER: (64467) 314	ea	1
19	5975-00-878-3791	ROD, GROUND: (82370) A104	ea	1
20	2330-01-076-4797	SEMITRAILER, FLATBED, CHASSIS: (97403) TL/MIL-B-13207, par. 3.11 fig. 12, tables III and IV	ea	1

Section II COMPONENTS OF END ITEM - Cont

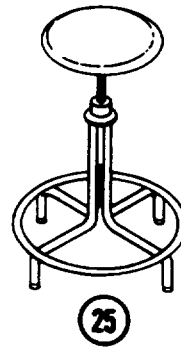
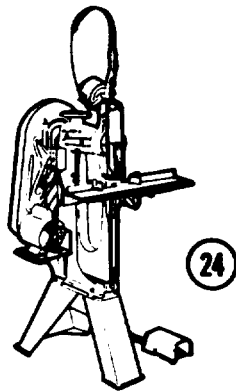
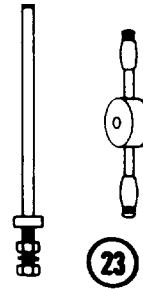
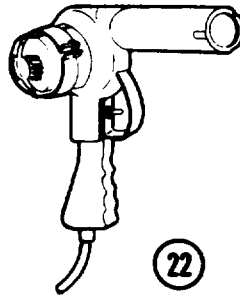
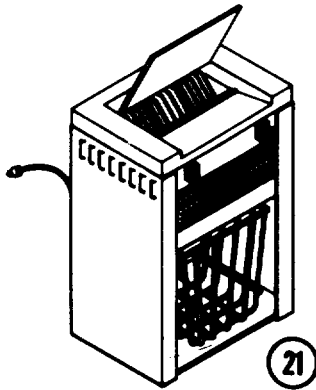

(1) Illus Number	(2) National Stock Number	(3) Description FSCM and Part Number	(4) U/M	(5) Qty Rqr
21	3615-01-171-3309	SHREDDER, PAPER CUTTER: (96153) Model 48	ea	1
22	3540-01-112-3225	SHRINK WRAP SYSTEM: (59164) Model EP-7, w/Stand Bench and Carrying Case	ea	1
23	5120-01-013-1676	SLIDE HAMMER, GROUND ROD EMPLACEMENT: (45225) P74-144	ea	1
24	3610-00-174-1715	STITCHER, BOOK AND PAMPHLET: (08075) 7, size 0.875 in. cap.	ea	1
25	7110-00-634-8596	STOOL, REVOLVING: (09177) 60-100	ea	2

Section II COMPONENTS OF END ITEM - Cont

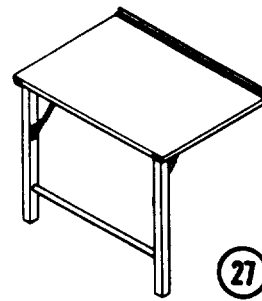
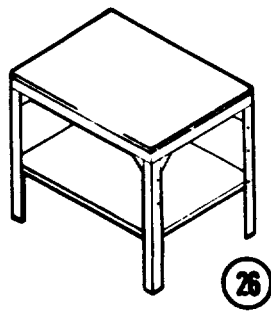

(1) Illus Number	(2) National Stock Number	(3) Description FSCM and Part Number	(4) U/M	(5) Qty Rqr
26	3610-00-203-2056	TABLE, BINDERY, PAPER: (26954) MIL-T-52803	ea	1
27		TABLE, FOLDING: (97403) 13225E3135	ea	3

Section III BASIC ISSUE ITEMS

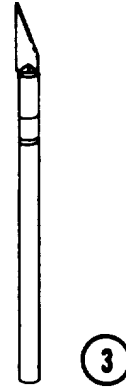
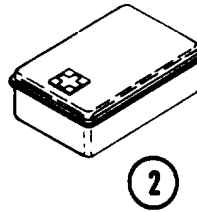

(1) Illus Number	(2) National Stock Number	(3) Description FSCM and Part Number	(4) U/M	(5) Qty Rqr
		BLOCK, CUTTING: (11444) A4682	pg	1
	5920-00-205-0565	BRUSH, LENS (17866) R698	ea	1
	7920-00-291-5815	BRUSH, WIRE, SCRATCH: (39428) 7187T2	ea	1
1	4210-00-555-8837	EXTINGUISHER, FIRE, MONOBROMO- TRIFLUROMETHANE: (33525) T2	ea	2
2	4240-00-439-3450	FACE SHIELD, INDUSTRIAL: (81348) L-F-36	ea	1
	6545-00-922-1200	FIRST AID KIT, GENERAL PURPOSE: (89875) SC C-6545-IL vol 2	ea	1
	4240-00-052-3776	GOGGLES, SAFETY: (58536) A-A-1110	ea	1
	5120-00-596-1071	HAMMER, SOFT FACE (81348) GGG-H-33 TYP1 CL3 STYD	ea	1
	4930-00-277-1547	HAND OILER: (81348) GGG-O-591 TYP1 CL6	ea	1
3	5120-01-046-5079	KEY SET, SOCKET HEAD SCREW: 2 mm to 19 mm (55719) AWM-140C-K	se	1
	5110-00-595-8400	KNIFE, CRAFTSMAN'S: (99941) 3001	ea	2

Section III BASIC ISSUE ITEMS —Cont

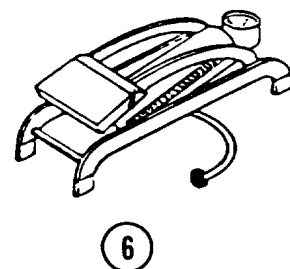
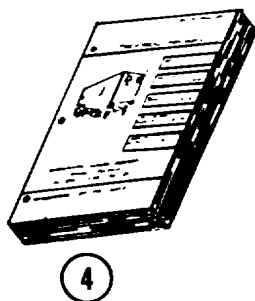

(1) Illus Number	(2) National Stock Number	(3) Description FSCM and Part Number	(4) U/M	(5) Qty Rqr
4	7520-01-008-7640	LEAD REPOINTER, PENCIL: (79819) 992WB MANUALS, TECHNICAL: LO 5-3610-253-12, Lubrication Order, TSS Finishing Section TM 5-3610-253-14, Operator's, Organiza- tional, Direct Support and General Support Maintenance Manual, TSS Finishing Section TM 5-3610-253-24P, Repair Parts and Special Tools List, TSS Finishing Section	ea	2
5	5340-00-682-1505	PADLOCK SET: (77765) MS 21313-52	se	1
	5120-00-268-3579	PLIERS, NEEDLE NOSE: (81348) GGG-P-471 TYP XI CL1 STYB PUMP, HAND, MULTI-PURPOSE: (25795) 2P138	ea	1
6		PUMP, INFLATING, MANUAL: (53800) 6A 49454	ea	1
7		RULE, STEEL, MACHINIST'S: (57163) CME 600	ea	1

Section III BASIC ISSUE ITEMS

—Cont



8



9

(1) Illus Number	(2) National Stock Number	(3) Description FSCM and Part Number	(4) U/M	(5) Qty Rqr
8	5120-00-234-8913	SCREWDRIVER, CROSS TIP: size 2 (81348) GGG-S-121	ea	1
9	5120-00-222-8852	SCREWDRIVER, FLAT TIP: (81348) GGG-S-121	ea	1
		STRAP ASSEMBLY, BUCKLE-END: 6.0 in. (82820) 1844-104	ea	5
		STRAP ASSEMBLY, BUCKLE-END: 8.0 in. (82820) 1844-101	ea	1
		STRAP ASSEMBLY, BUCKLE-END: 15.0 in. (82820) 1844-105	ea	3
		STRAP ASSEMBLY: TIP-END: 8.0 in. (82820) 1845-107	ea	2
		STRAP ASSEMBLY: TIP-END: 20.0 in. (82820) 1845-102	ea	2
		STRAP ASSEMBLY: TIP-END: 36.0 in. (82820) 1845-106	ea	1
		STRAP ASSEMBLY: TIP-END: 40.0 in. (82820) 1845-101	ea	3

Section III BASIC ISSUE ITEMS — Cont

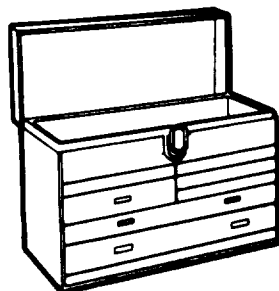

10

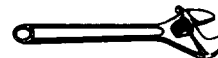

11

(1) Illus Number	(2) National Stock Number	(3) Description FSCM and Part Number	(4) U/M	(5) Qty Rqr
		STRAP ASSEMBLY: TIP-END: 72.0 in. (82820) 1845-104	ea	1
		STRAP ASSEMBLY: WEBBING: 30.00 in. (98313) 13225E3695-8	ea	1
		STRAP ASSEMBLY: WEBBING: 45.00 in. (98313) 13225E3695-3	ea	2
		STRAP ASSEMBLY: WEBBING: 55.00 in. (98313) 13225E3695-6	ea	4
		STRAP ASSEMBLY: WEBBING: 94.00 in. (98313) 3225E3695-10	ea	1
		STRAP ASSEMBLY: WEBBING: 29.00 in. (98313) 13225E3695-13	ea	2
		T-HANDLE KEY (C0347) 92/40.00.014555	ea	1
10	5140-00-315-2747	TOOL BOX, PORTABLE: (75206) CS 16	ea	1
11	5120-00-264-3795	WRENCH, ADJUSTABLE: (92878) 1500559	ea	1
		WRENCH COMBINATION 3/4 in. (47805) GGG-H-33 TYP1CL3STYD	ea	1

APPENDIX D

ADDITIONAL AUTHORIZATION LIST

Section I INTRODUCTION

D-1. SCOPE.

This appendix lists additional items you are authorized for the support of the Finishing Section.

D-2. GENERAL.

This list identifies items that do not have to accompany the Finishing Section and that do not have to be turned in with it. These items are all authorized to you by CTA, MTOE, TDA or JTA.

D-3. EXPLANATION OF LISTING.

National stock numbers, descriptions and quantities are provided to help you identify and request the additional items you require to support this equipment. The items are listed in alphabetical sequence by item name under the type document (i.e., CTA, MTOE, TDA, or JTA) which authorizes the item(s) to you.

Section II. ADDITIONAL AUTHORIZATION LIST

(1) National Stock Number	(2) Description FSCM and Part Number	(3) U/M	(4) Qty Auth
5805-00-543-0012	<p style="text-align: center;"><u>TOE AUTHORIZED ITEMS</u></p> <p>Telephone Set: TA-312/PT</p>	ea	1

APPENDIX E

EXPENDABLE/DURABLE SUPPLIES AND MATERIALS LIST

Section I INTRODUCTION

E-1 . SCOPE.

This appendix lists expendable/durable supplies and materials you will need to operate and maintain the Finishing Section. This listing is for information purposes only and is not authority to requisition the listed items. These items are authorized to you by CTA 50-970, Expendable/Durable Items (except Medical, Class V, Repair Parts and Heraldic Items), or CTA 8-100, Army Medical Department Expendable/Durable Items.

E-2. EXPLANATION OF COLUMNS

a. *Column (1) - Item Number.* This number is assigned to the entry in the listing and is referenced in the narrative instructions to identify the material (e.g., "Use cleaning compound, Item 5, Appendix E.").

b. *Column (2) - Level.* This column identifies the lowest level of maintenance that requires the listed item.

C - Operator/Crew

O - Organizational Maintenance

F - Direct Support Maintenance

H - General Support Maintenance

c. *Column (3) - National Stock Number.* This is the National stock number assigned to the item; use it to request or requisition the item.

d. *Column (4) - Description.* Indicates the Federal item name and, if required, a description to identify the item. The last line for each item indicates the part number followed by Federal Supply Code for Manufacturer (FSCM) in parentheses followed by the part number.

e. *Column (5) - Unit of Measure (U/M).* Indicates the measure used in performing the actual maintenance function. This measure is expressed by two-character alphabetical abbreviations (e.g., ea, in, pr). If the unit of measure differs from the unit of issue, requisition the lowest unit of issue that will satisfy your requirements.

Section II EXPENDABLE/DURABLE SUPPLIES AND MATERIALS LIST

(1) Item Number	(2) Level	(3) National Stock Number	(4) Description	(5) U/M
1	C	6810-00-223-2739	Acetone, Technical	cn
2	O	8040-00-174-2610	Adhesive, Rubber	cn
3	F	8040-00-152-0063	Adhesive, Waterproof	cn
	C	8105-00-702-7175	Bag, Plastic	ro
	C		Basket, Wastepaper (39428) 4016T2	ea
	C	9160-00-253-1171	Beeswax, Technical (59148) genuine pure beeswax specification	lb
	C	5110-00-359-6478	Blade, Craftsman Knife: Beveled (99941) 11	pg
	C	5110-00-542-2043	Blade, Craftsman Knife: Curved (99941) 10	pg
	C	5110-00-542-2044	Blade, Craftsman Knife: Square (99941) 17	pg
	C	5110-00-765-4144	Blade, Craftsman Knife: Stencil (99941) 16	pg
4	C		Carborundum Pencil (11444) 4686	ea
5	C	6850-00-592-3283	Cleaner, Lens	bk
6	C	8305-00-222-2423	Cloth, Cheesecloth	yd
7	C	6515-00-303-8250	Cotton Swabs	bg
	C		Cutting Sticks (D2530) 219618	ct
8	C	7930-00-530-8067	Detergent, General Purpose	gl
	C	7520-00-285-8078	Dispenser, Pressure Sensitive Adhesive (07163) GG-D-458, type I, class 1	ea

Section II EXPENDABLE/DURABLE SUPPLIES AND MATERIALS LIST - Cont

(1) Item Number	(2) Level	(3) National Stock Number	(4) Description	(5) U/M
9	F	5610-00-618-0258	Floor Patch	gl
10	F	9150-00-754-2635	Gear Oil, 90W	qt
	C	8415-00-641-4601	Gloves, Impermeable	pr
11	O	9150-00-190-0904	Grease, GAA	lb
12	O	9150-00-935-9807	Hydraulic Fluid, OHA	qt
	C	7510-00-285-5866	Lead Pencil, Graphite H (79819) 2200-H	bx
	C	7510-00-272-9820	Lead Pencil, Graphite 3H (79819) 2200-3H	bx
	C	7510-00-231-6846	Lead, Pencil, Graphite (79819) 2222-5H	bx
13	C	6640-00-597-6745	Lens Tissue	bk
14	O	8030-00-252-3391	Liquid Gasket	tu
15	C		Lubricant, Stick (11444) 4688	ea
16	F	9150-00-273-2389	Oil, Lubricating, General Purpose	cn
17	C	9150-00-186-6681	Oil, Lubricating, HDO	qt
	C	7240-00-137-1608	Pail, Utility (19272) 4 gal.	ea
18	O	8010-01-131-6254	Paint, Black	kt
18A	O	8010-01-160-6745	Paint, Brown	kt
18B	O	8010-01-162-5578	Paint, Green	kt
19	O	8010-00-298-3859	Paint, Light Green, INT.	gl
20	C	5350-00-619-9166	Paper, Abrasive	pg

Section II EXPENDABLE/DURABLE SUPPLIES AND MATERIALS LIST-Cont

(1)	(2)	(3) National Stock Number	(4)	(5)
Item Number	Level		Description	U/M
	C	8135-00-160-7776	Paper, Kraft, Untreated (39428) 1916T	ro
	C	7510-00-240-1526	Pencil: black (79819) 1555, black	dz
	C	7510-00-436-5210	Pencil: blue (79819) 1555, blue	dz
	C	7510-00-174-3205	Pencil: red (79819) 1555, red	dz
	C	7520-01-083-6734	Pencil, Mechanical (79819) 5611	ea
	O	8010-01-193-0520	Primer	kt
21	O	7920-00-205-1711	Rags	be
22	F	8010-01-030-7254	Resin, Epoxy	kt
23	O	5350-00-221-0884	Sandpaper, Med. Grit	pg
24	O	FSCM 39428	Screen, Nylon (P/N 1017A31)	ro
25	O	8040-00-851-0211	Sealant, Silicone	tu
	C	7520-00-162-6178	Sharpener, Pencil (79819) U8-1031 Model KS	ea
	C	5110-00-162-2207	Shears, Straight Trimmers (79819) Q9-3762	ea
26	O	6850-00-274-5421	Solvent, P-D-680	cn
27	C	6850-00-880-1013	Spray, Silicone	cn
28	O	FSCM 39428	Sprayfoam Sealant (P/N 7627T1)	cn
	O	6670-00-238-9777	Spring Scale	ea
	C	7520-00-281-5895	Stapler, Paper Fastening, Office: (8D190) X8-27, grey	ea

Section II EXPENDABLE/DURABLE SUPPLIES AND MATERIALS LIST - Cont

(1) Item Number	(2) Level	(3) National Stock Number	(4) Description	(5) U/M
	C	7510-00-272-9662	Staples, Paper Fastening, Office Type (8D190) 8-SF4-5M	bx
29	O	5640-00-103-2254	Tape, Cloth, Duck Sealing, 2 in.	ro
	C	7510-00-297-6655	Tape, Pressure Sensitive Adhesive (76381) 3750, 2.0 in. w	ro
	C	7510-00-290-8036	Tape, Pressure Sensitive Adhesive (76381) 898, 1.0 in. w	ro
	C	4020-00-247-1737	Twine, Fibrous (73786) MIL-T-713, type N, class 1	lb
	C	7240-00-965-4427	Waste Receptacle, Removable Open Top Type (39428) 4464T14	ea
30	O	7930-00-281-3267	Wax, Automotive	cn

PIN: 058778-001

GLOSSARY

ABBREVIATION/TERM	DEFINITION
Bind	Stitch.
NC	Normally closed.
OCL	Optical Cutting Line Indicator.
OMI	Optical Measurement Indicator.
PC	Printed Circuit (Card).
Saddle Stitch	To stitch on fold so that stitches are in spine or center of book or pamphlet.

INDEX

SUBJECT	PARAGRAPH
FINISHING SECTION	
A	
Air Conditioner/Heater, Replace	1-20. 8
Air Conditioner Support Bracket, Replace	1-20. 9
Air Vent Cover, Replace	1-16. 17
Air Vent Screen, Replace	1-16. 16
B	
Ballast, Fluorescent Lamp, Replace	1-16. 1
Blackout/Dome Light, Replace	1-10. 3
Blackout/Dome Light Microswitch, Replace	1-16. 5
Blackout Curtain, Repair	1-16. 2
Breaker, Circuit, Replace	1-20. 5
C	
Cargo Door Latch Assembly, Replace	1-20. 2
Characteristics, Capabilities, and Features	1-2. 1
Circuit Breaker, Replace	1-20. 5
Common Tools and Equipment	1-12, 1-18
Components, Location and Description of Major	1-2. 2
Conditions, Operation Under Unusual	1-7
Conditions, Operation Under Usual	1-6
Cover, Air Vent, Replace	1-16. 17
Cover, Exhaust Fan, Replace	1-16. 10
Curtain, Blackout, Repair	1-16. 12
D	
Data, Equipment	1-2. 3
Description and Use of Operator's Controls and Indicators.	1-4
Destruction of Material to Prevent Enemy Use	1-1. 5
Door, Personnel /Cargo, Replace	1-20. 4
Door Handle, Personnel, Repair	1-20. 1
Duct, Ventilation, Replace	1-20. 10
Ducts, Ventilation, Service	1-10. 2
E	
Emergency Light Assembly, Replace	1-16. 11
Equipment Data.	1-2. 3
Equipment Description	1-2
Equipment Characteristics, Capabilities, and Features	1-2. 1
Exhaust Fan, Replace.	1-16. 9
Exhaust Fan Cover, Replace	1-16. 10

INDEX - Cont

SUBJECT PARAGRAPH
 FINISHING SECTION - Cont

F

Fan, Exhaust, Replace	1-16.9
Features, Equipment Characteristics, Capabilities, and	1-2.1
Filter, Radio Frequency (RF), Replace	1-16.2
Floor Covering, Repair	1-20.6
Fluorescent Lamp, Replace	1-10.1
Fluorescent Lamp Ballast, Replace	1-16.1
Fluorescent Lamp Switch, Replace	1-16.3
Forms and Records, Maintenance	1-1.3

G

General Information	1-1
-------------------------------	-----

I

Indicator, Level, Repair	1-16.15
Indicators, Description and Use of Operator's Controls and	1-4
Instructions, Lubrication	1-8, 1-11

L

Ladder, Personnel, Repair	1-16.18
Level Indicator, Repair	1-16.15
Light, Blackout/Dome, Replace	1-10.3
Light, Emergency Assembly, Replace	1-16.11
Location and Description of Major Components	1-2.2
Lubrication Instructions	1-8, 1-11

M

Maintenance Procedures	1-10, 1-16, 1-20
Maintenance Forms and Records	1-1.3
Microswitch, Blackout/Dome Light, Replace	1-16.5
Molding, Wire, Replace	1-16.7

O

On/Off Switch, Replace	1-16.4
Operations, Technical Principles of	1-3
Operation Under Unusual Conditions	1-7
Operation Under Usual Conditions	1-6
Operator's Controls and Indicators, Description and Use of	1-4
Operator Preventive Maintenance Checks and Services	1-5
Organizational Preventive Maintenance Checks and Services	1-14
Organizational Troubleshooting	1-15

INDEX - Cont

SUBJECT PARAGRAPH
 FINISHING SECTION - Cont

P

Parts, Repair	1-12, 1-18
Personnel Door Handle, Repair	1-20.1
Personnel /Cargo Door, Replace	1-20.4
Personnel /Cargo Door Gasket, Replace	1-20.3
Personnel Ladder, Repair	1-16.18
Preparation for Movement	1-6.2
Preparation for Storage or Shipment	1-17
Preventive Maintenance Checks and Services	1-5, 1-14
Procedures, Maintenance	1-10, 1-16, 1-20

R

Radio Frequency (RF) Filter, Replace	1-16.2
Receipt, Service Upon	1-13
Receptacle, Replace	1-16.6
Repair Parts	1-12, 1-18
Repair:	
Blackout Curtain	1-16.12
Floor Covering	1-20.6
Level Indicator	1-16.15
Personnel Door Handle	1-20.1
Personnel Ladder	1-16.18
Telephone Binding Post Assembly	1-16.8
Van Body Skin	1-16.12, 1-20.7
Replace:	
Air Conditioner/Heater	1-20.8
Air Conditioner Support Bracket	1-20.9
Air Vent Cover	1-16.17
Air Vent Screen	1-16.16
Blackout/Dome Light	1-10.3
Blackout/Dome Light Microswitch	1-16.5
Cargo Door Latch Assembly	1-20.2
Circuit Breaker	1-20.5
Emergency Light Assembly	1-16.11
Exhaust Fan	1-16.9
Exhaust Fan Cover	1-16.10
Fluorescent Lamp	1-10.1
Fluorescent Lamp Ballast	1-16.1
Fluorescent Lamp Switch	1-16.3
On/Off Switch	1-16.4
Personnel /Cargo Door	1-20.4
Personnel /Cargo Door Gasket	1-20.3
Radio Frequency (RF) Filter	1-16.2
Receptacle	1-16.6
Tiedown Socket	1-16.14
Ventilation Duct	1-20.10
Wire Molding	1-16.7

INDEX - Cont

SUBJECT PARAGRAPH

FINISHING SECTION - Cont

S

Scope	1-1.1
Service Upon Receipt	1-13
Service Ventilation Ducts	1-10.2
Services, Preventive Maintenance Checks and	1-5, 1-14
Shipment, Preparation for Storage or	1-17
Socket, Tiedown, Replace	1-16.14
Special Tools; Test, Measurement, Diagnostic and Support Equipment.	1-12, 1-18
Switch, Fluorescent Lamp, Replace	1-16.3
Switch, On/Off, Replace	1-16.4

T

Technical Principles of Operation	1-3
Telephone Binding Post Assembly, Repair	1-16.8
Tiedown Socket, Replace	1-16.14
Tools and Equipment, Special	1-12, 1-18
Tools; Test, Measurement, Diagnostic and Support Equipment, Special	1-12, 1-18
Troubleshooting	1-9, 1-15, 1-19

V

Van Body Skin, Repair	1-16.13. 1-20.7
Ventilation Duct, Replace	1-12.10
Ventilation Ducts, Service	1-10.2

W

Wire Molding, Replace	1-16.7
---------------------------------	--------

FURNITURE AND CABINETS

B

Bindery Table	8-2
Bindery Table, Remove/Install	8-16.8

C

Cabinet, Five Drawer Photolithographic	8-2
Cabinet, Five Drawer Photolithographic, Remove/Install	8-16.10
Cabinet, One Drawer Photolithographic.	8-2
Cabinet, One Drawer Photolithographic, Remove/Install.	8-16.11

INDEX - Cont

SUBJECT PARAGRAPH

FURNITURE AND CABINETS - Cont

C - Cont

Cabinet, Wall Storage	8-2
Cabinet, Wall Storage, Remove/Install	8-16.1
Chair, Folding	8-2
Corkboard	8-2
Corkboard, Remove/Install	8-16.7

D

Description, Equipment	8-2
Door Hinge (Piano Hinge), Replace	8-16.3
Door Latch (Wall Storage Cabinet), Replace	8-16.2

E

Equipment Description	8-2
---------------------------------	-----

F

Five Drawer Photolithographic Cabinet	8-2
Five Drawer Photolithographic Cabinet, Remove/Install	8-16.10
Folding Chair	8-2
Folding Table	8-2
Folding Table, Remove/Install	8-16.9
Furniture and Cabinets, Inspect	8-10.1

G

General Information	8-1
-------------------------------	-----

H

Hinge, Replace	8-16.5
Hinge (Piano), Replace	8-16.3

I

Information, General	8-1
Inspect Furniture and Cabinets	8-10.1
Instructions, Lubrication	8-8, 8-11

L

Latch (Flush Type) Replace	8-16.4
Leg Supports, Replace	8-16.6
Lubrication Instructions	8-8, 8-11

INDEX - Cont

SUBJECT PARAGRAPH
 FURNITURE AND CABINETS - Cont

M

Maintenance Procedures 8-10, 8-16
 Movement, Preparation for 8-6.1

O

One Drawer Photolithographic Cabinet 8-2
 One Drawer Photolithographic Cabinet, Remove/Install 8-16.11
 Operation, Technical Principles of 8-3
 Operation Under Unusual Conditions 8-7
 Operation Under Usual Conditions 8-6
 Operator's Controls and Indicators, Description and Use of 8-4

P

Preparation for Movement 8-6.1
 Preparation for Storage or Shipment 8-17
 Preventive Maintenance Checks and Services 8-5, 8-14
 Procedures, Maintenance 8-10, 8-16

R

Remove/Install:
 Bindery Table 8-16.8
 Corkboard 8-16.7
 Five Drawer Photolithographic Cabinet 8-16.10
 Folding Table 8-16.9
 One Drawer Photolithographic Cabinet 8-16.11
 Wall Storage Cabinet 8-16.1
 Replace:
 Hinge 8-16.5
 Hinge (Piano) 8-16.3
 Latch (Flush Type) 8-16.4
 Latch (Wall Storage Cabinet) 8-16.2
 Leg Supports. 8-16.6
 Revolving Stool 8-2

S

Scope 8-1.1
 Service Upon Receipt 8-13
 Stool, Revolving 8-2
 Supports, Leg, Replace 8-16.6
 Shipment, Preparation for Storage or 8-17

INDEX - Cont

SUBJECT PARAGRAPH

FURNITURE AND CABINETS - Cont

T

Table, Bindery 8-2
 Table, Bindery, Remove/Install 8-16.8
 Table, Folding 8-2
 Table, Folding, Remove/Install 8-16.9
 Troubleshooting 8-9, 8-15

W

Wall Storage Cabinet. 8-2
 Wall Storage Cabinet, Remove/Install 8-16.1

MASON-TYPE PSYCHROMETER

D

Data, Equipment 7-2.2
 Description, Equipment 7-2
 Description and Use of Operator's Controls
 and Indicators. 7-4

E

Equipment Data. 7-2.2
 Equipment Description 7-2
 Equipment Characteristics, Capabilities, and
 Features. 7-2.1

G

General Information 7-1

I

Indicators, Description and Use of
 Operator's Controls and 7-4
 Information, General 7-1
 Instructions, Lubrication 7-8, 7-11

L

Lubrication Instructions 7-8, 7-11

INDEX - Cont

SUBJECT PARAGRAPH
 MASON-TYPE PSYCHROMETER - Cont

O

Operation, Technical Principles of 7-3
 Operation Under Unusual Conditions 7-7
 Operation Under Usual Conditions 7-6

P

Preparation for Storage or Shipment 7-17
 Preventive Maintenance Checks and Services 7-5, 7-14

S

Scope 7-1. 1
 Service Upon Receipt 7-13
 Services, Preventive Maintenance Checks and 7-5, 7-14
 Shipment, Preparation for Storage or 7-17

T

Technical Principles of Operation 7-3
 Troubleshooting 7-9, 7-15

PAPER CUTTER (92-CS)

A

A Motherboard PC Card, Replace 5-20. 12
 A Plug-In Pc Card, Replace 5-20. 11
 Adjust:
 Backgauge. 5-16. 22
 Backgauge Angle 5-16. 25
 Clamp Connecting Rod 5-16. 26
 Clamp Guiding 5-20. 22
 Clamp Pressure 5-20. 20
 Clutch Pressure 5-20. 21
 Foot Pedal Pressure. 5-20. 19
 Sledge Guides 5-16. 23
 Table Stop Bolts and **Limit Switches.** 5-16. 24
 Assembly and Preparation for Use 5-16. 23

B

Backgauge, Adjust. 5-16. 22
 Backgauge Angle, Adjust 5-20. 25
 Backgauge Brake Pads, Replace. 5-20. 13
 Backgauge Limit Switches, Replace. 5-16. 9

INDEX - Cont

SUBJECT	PARAGRAPH
PAPER CUTTER (92-CS) - Cont	

B - Cont

Backgauge Control Switches, Replace	5-16.14
Backgauge Motor, Replace	5-16.7
Backgauge Overload Relay, Replace	5-16.8
Bleed Hydraulic System	5-20.23

C

Check Clearance Between Knife and Clamp	5-20.1
Checks and Services, Preventive Maintenance	5-5, 5-14
Clamp Connecting Rod, Adjust	5-16.26
Clamp Cylinder, Replace	5-20.8
Clamp Guiding, Adjust	5-20.22
Clamp Foot Pedal, Replace	5-16.10
Clamp Pedal Switch, Replace	5-16.12
Clamp Return Spring, Replace	5-16.11
Clamp Pressure, Adjust	5-20.20
Clutch Pressure, Adjust	5-20.21
Components, Location and Description of Major	5-2.2
Conditions, Operation Under Unusual	5-7
Conditions, Operation Under Usual	5-6
Connecting Rod Assembly, Replace	5-20.16
Connecting Rod Shear Bolts, Replace	5-16.14
Control Block, Replace	5-20.2
Control Power On Switch, Replace	5-16.15
Control Transformer, Replace	5-20.9
Control Valve, Replace	5-20.3
Cutting Buttons, Replace	5-16.16
Cutting Stick, Rotate or Replace	5-10.3

D

Data, Equipment	5-2.3
Description, Equipment	5-2
Description and Use of Operator's Controls and Indicators.	5-4

E

Equipment Data	5-2.3
Equipment Description	5-2
Equipment Characteristics, Capabilities and Features	5-2.1

INDEX - Cont

SUBJECT	PARAGRAPH
PAPER CUTTER (92-CS) - Cont	
F	
False Clamp Switch, Replace	5-20. 15
Features, Equipment Characteristics, Capabilities, and	5-2. 1
Foot Pedal Pressure, Adjust	5-20. 19
Fluorescent Lamp, Replace	5-10. 4
G	
Gear Limit Switches, Replace	5-16. 18
General Information	5-1
Glass Rule, Replace	5-10. 2
H	
Hydraulic Cylinder Suction Hose, Replace	5-20. 4
Hydraulic Fluid Filter, Service	5-20. 6
Hydraulic Pump, Replace.	5-20. 5
Hydraulic System, Bleed	5-20. 23
I	
Indicators, Description and Use of Operator's Controls and	5-4
Information, General	5-1
Information, Reference	5-1. 2
Instructions, Lubrication	5-8, 5-11
K	
Knife and Clamp, Check Clearance Between	5-20. 1
Knife Carrier Movement, Manual	5-16. 27
Knife, Replace	5-16. 13
L	
Left Light Barrier Assembly, Repair	5-16. 19
Location and Description of Major Components	5-2. 2
Lubrication Instructions	5-8, 5-11

INDEX - Cont

SUBJECT	PARAGRAPH
PAPER CUTTER (92-CS) - Cont	
M	
Maintenance Procedures	5-10, 5-16, 5-20
Main Circuit Breaker, Replace	5-20.24
Main Distributor HP Card, Replace	5-20.10
Main Drive Gear and Clutch Assembly, Replace	5-20.17
Main Drive Gear Clutch Pads, Replace	5-16.1
Main Drive Gear Clutch Brakes, Replace	5-16.2
Main Drive Motor, Replace	5-16.5
Main Drive Motor Overload Relay	1-16.3
Main Drive Motor V-Belts, Replace	5-16.4
Main Power Switch, Replace	5-16.15
Manually Move Knife Carrier	5-16.27
Movement, Preparation for	5-6.3
O	
OCL Lamp, Replace	5-10.5
OMI Bulb, Replace	5-10.1
Operating Procedures	5-6.2
Operation, Technical Principles of	5-3
Operation Under Unusual Conditions	5-7
Operation Under Usual Conditions	5-6
P	
Paper Cutter, Replace	5-20.18
Plug-in PC Card, A, Replace	5-20.11
Preparation for Movement	5-6.3
Preparation for Storage or Shipment	5-17
Preparation for Use, Assembly and	5-6.1
Preventive Maintenance Checks and Services	5-5, 5-14
Procedures, Maintenance	5-10, 5-16, 5-20
Procedures, Operating	5-6.2
R	
Reference Information	5-1.2
Repair Left Light Barrier Assembly	5-16.19
Repair Right Light Barrier Assembly	5-16.20
Repair Table Lamp	5-16.21
Replace:	
A Plug-in PC Card	5-20.11
Backgauge Brake Pads	5-20.13
Backgauge Limit Switches	5-16.9
Backgauge Control Switches	5-20.14
Backgauge Motor	5-16.7
Backgauge Motor V-Belt	5-16.6

INDEX - Cont

SUBJECT	PARAGRAPH
PAPER CUTTER (92-CS) - Cont	

R - Cont

Backgauge Overload Relay	5-16.8
Clamp Cylinder	5-20.8
Clamp Foot Pedal	5-16.10
Clamp Pedal Switch	5-16.12
Clamp Return Spring	5-16.11
Connecting Rod Assembly	5-20.16
Connecting Rod Shear Bolts	5-16.14
Control Block	5-20.2
Control Power On Switch	5-16.15
Control Transformer	5-20.9
Control Valve	5-20.3
Cutting Buttons	5-16.16
Cutting Stick	5-10.3
False Clamp Switch	5-20.15
Fluorescent Lamp	5-10.4
Gear Limit Switches	5-16.18
Glass Rule	5-10.2
Hydraulic Cylinder Suction Hose	5-20.4
Hydraulic Pump	5-20.5
Knife	5-16.13
Main Circuit Breaker	5-20.24
Main Distributor HP Card	5-20.10
Main Drive and Clutch Assembly	5-20.17
Main Drive Gear Clutch Pads	5-16.1
Main Drive Gear Clutch Brakes	5-16.2
Main Drive Motor	5-16.5
Main Drive Motor Overload Relay	5-16.3
Main Drive Motor V-Belts	5-16.4
Main Power Switch	5-16.15
Mother Board PC Card, A	5-20.12
OCL Lamp(s)	5-10.5
OMI Bulb	5-10.1
Paper Cutter	5-20.18
Retarding Valve	5-20.7
Safety Bolt Assembly	5-16.17
Starter	5-10.4
Retarding Valve, Replace	5-20.7
Right Light Barrier-Assembly, Repair	5-16.20
Rotate or Replace Cutting Stick	5-10.3

INDEX - Cont

SUBJECT PARAGRAPH

PAPER CUTTER (92-CS) - Cont

S

Scope	5-1. 1
Service Hydraulic Fluid Filter	5-20. 6
Service Upon Receipt	5-13
Safety Bolt Assembly, Replace	5-16. 17
Slide Guides, Adjust	5-16. 23
Starter, Replace.	5-10. 4

T

Table Lamp, Repair.	5-16. 21
Table Stop Bolts and Limit Switches, Adjust	5-16. 24
Technical Principles of Operation	5-3
Troubleshooting	5-9, 5-15, 5-19

PAPER CUTTER (92-SD)

A

Adjust :	
Backgauge	5-36. 15
Backgauge Angle	5-36. 20
Clamp Foot Pedal	5-36. 18
Clamp Foot Pedal Pressure	5-40. 55
Clamp Guiding	5-40. 64
Clamp Pressure.	5-40. 56
Clamp Proximity Switch (b29)	5-40. 59
Clamp Return Spring	5-36. 19
Clutch Pressure	5-40. 57
Gear Limit Switches (S22a and b)	5-40. 58
Light Barrier	5-40. 62
Main Motor V-Belt Tension	5-36. 14
Measurement Display	5-40. 60
Power Supplies.	5-40. 63
Safety Bolt Proximity Switches (SB. A and SB. E)	5-40. 61
Slide Guides	5-36. 16
Table Stop Bolt and Limit Switches	5-36. 17
AR Circuit Board for Input Power, Test	5-40. 15

B

Backgauge, Adjust	5-36. 15
Backgauge Angle, Adjust.	5-36. 20
Backgauge Brake, Replace	5-40. 37
Backgauge Control Switches, Replace	5-40. 38
Backgauge Limit Switches, Replace	5-40. 39
Backgauge Motor, Replace.	5-36. 7

INDEX - Cont

SUBJECT
 PAPER CUTTER (92-SD) - Cont

PARAGRAPH

B - Cont

Backgauge Motor V-Belts, Replace 5-36. 6
 Backgauge Overload Relay, Replace 5-36. 8
 Bleed Hydraulic System 5-40. 65

C

Check Clearance Between Knife and Clamp 5-40. 17
 Circuit Board ML, Replace 5-40. 29
 Circuit Board SDA, Replace. 5-40. 30
 Circuit Boards HK, KK, PS5, PS24 and TAM, Replace 5-40. 31
 Circuit Boards IAR and/or AR, Replace 5-40. 28
 Clamp Cylinder, Replace 5-40. 23
 Clamp Foot Pedal, Adjust. 5-36. 18
 Clamp Foot Pedal, Replace 5-36. 9
 Clamp Foot Pedal Pressure, Adjust 5-40. 55
 Clamp Foot Pedal Switch, Replace 5-40. 41
 Clamp Foot Pedal Switch (S309), Test 5-40. 7
 Clamp Guiding, Adjust 5-40. 64
 Clamp Pressure, Adjust 5-40. 56
 Clamp Proximity Switch, Replace 5-40. 42
 Clamp Proximity Switch (b29), Adjust 5-40. 59
 Clamp Proximity Switch (b29), Test 5-40. 6
 Clamp Return Spring, Adjust 5-36. 19
 Clamp Return Spring, Replace 5-36. 10
 Clamping Pressure Adjustment Cable, Replace 5-40. 27
 Clutch Pressure, Adjust 5-40. 57
 Connecting Rod Assembly, Replace 5-40. 44
 Connecting Rod Shear Bolt, Replace 5-36. 12
 Control Panel, Repair 5-40. 53
 Cutting Buttons, Replace 5-40. 49
 Cutting Buttons (S28a and b), Test 5-40. 1
 Cutting Stick, Replace 5-30. 1

D

Data, Equipment 5-22. 3
 Description and Use of Operator's Controls and Indicators 5-24
 Description, Equipment 5-22

E

Equipment Characteristics, Capabilities, and Features 5-22. 1
 Equipment Data 5-22. 3
 Equipment Description 5-22

INDEX - Cont

SUBJECT	PARAGRAPH
PAPER CUTTER (92-SD) - Cont	
F	
False Clamp Switch, Replace	5-40.43
Features, Equipment Characteristics, Capabilities, and	5-22.1
Fluorescent Lamp or Starter, Replace	5-30.2
G	
Gear Limit Switches, Replace	5-40.45
Gear Limit Switches (S22a and b), Adjust	5-40.58
Gear Limit Switches (S22a and b), Test	5-40.5
General Information	5-21
H	
HK Circuit Board for Input Power, Test	5-40.12
Hydraulic Control Block, Replace	5-40.22
Hydraulic Pump, Replace	5-40.24
I	
IAR Circuit Board for Input Power, Test	5-40.11
IAR to AR Ribbon Cable, Replace	5-40.33
Inch Valve, Replace	5-40.21
Inch Valve Cable, Replace	5-40.26
Indicators, Description and Use of Operator's Controls and	5-24
Information, General	5-21
Information, Reference	5-21.1
Inputs and Outputs of MC Unit Plug Connectors, Test	5-40.16
Instructions, Lubrication	5-28, 5-31
K	
KK Circuit Board for Input Power, Test	5-40.14
Knife, Replace	5-36.11
Knife Changing Switch (S340), Test	5-40.13
L	
Left Light Barrier Assembly, Repair	5-40.52
Light Barrier, Adjust	5-40.62
Light Barrier Outputs/Inputs, Test	5-40.2
Linear Scale Measurement Device, Replace	5-40.40
Locking Valve M1 or Clamping Valve M2, Replace	5-40.20
Location and Description of Major Components	5-22.2
Lubrication Instructions	5-28, 5-31

INDEX - Cont

SUBJECT PARAGRAPH

PAPER CUTTER (92-SD) - Cont

M

Main Drive Gear Clutch Assembly, Replace	5-40. 46
Main Drive Gear Clutch Brakes, Replace	5-36. 2
Main Drive Gear Clutch Pads, Replace	5-36. 1
Main Drive Motor, Replace	5-36. 5
Main Drive Motor Overload Relay, Replace	5-36. 3
Main Drive Motor V-Belts, Replace	5-36. 4
Main Motor V-Belt Tension, Adjust	5-36. 14
Maintenance Procedures	5-30, 5-36, 5-40
Manually Move Knife Carrier	5-36. 21
MC Unit Electronic Relays, Replace	5-40. 36
MC Unit Motherboard, Replace	5-40. 35

O

OCL Lamp(s), Replace	5-30. 3
Operating Procedures	5-26. 1
Operation Under Unusual Conditions	5-27
Operation Under Usual Conditions	5-26
Operator's Controls and Indicators, Description and Use of	5-24
Output of HK Board to Safety Bolt (Y.SB), Test	5-40. 4

P

P1 Block, Replace	5-40. 18
P2 Block, Replace	5-40. 19
Paper Cutter, Replace	5-40. 50
Power Module Assembly, Repair	5-40. 54
Power Supplies, Adjust	5-40. 63
Preparation for Movement	5-26. 2
Preparation for Storage or Shipment	5-37
Preventive Maintenance Checks and Services	5-25, 5-34
Procedures, Maintenance	5-30, 5-36, 5-40
Procedures, Operating	5-26. 1

R

Reference Information	5-21. 1
Repair:	
Control Panel	5-40. 53
Left Light Barrier Assembly	5-40. 52
Power Module Assembly	5-40. 54
Right Light Barrier Assembly	5-40. 51
Table Lamp.	5-36. 13
Replace:	
Backgauge Brake.	5-40. 37
Backgauge Control Switches	5-40. 38

INDEX - Cont

SUBJECT
 PAPER CUTTER (92-SD) - Cont

R - Cont

Backgauge Limit Switches	5-40.39
Backgauge Motor	5-36.7
Backgauge Motor V-Belts	5-36.6
Backgauge Overload Relay	5-36.8
Circuit Board ML	5-40.29
Circuit Board SEA	5-40.30
Circuit Boards HK, KK, PS5, PS24 and TAM	5-40.31
Circuit Boards IAR and/or AR	5-40.28
Clamp Cylinder	5-40.23
Clamp Foot Pedal	5-36.9
Clamp Foot Pedal Switch	5-40.41
Clamp Proximity Switch	5-40.42
Clamp Return Spring	5-36.10
Clamping Pressure Adjustment Cable	5-40.27
Connecting Rod Assembly	5-40.44
Connecting Rod Shear Bolt	5-36.12
Cutting Buttons	5-40.49
Cutting Stick	5-30.1
False Clamp Switch	5-40.43
Fluorescent Lamp or Starter	5-30.2
Gear Limit Switches	5-40.45
Hydraulic Control Block	5-40.22
Hydraulic Pump	5-40.24
IAR to AR Ribbon Cable	5-40.33
Inch Valve	5-40.21
Inch Valve Cable	5-40.26
Knife	5-36.11
Linear Scale Measurement Device	5-40.40
Locking Valve M1 or Clamping Valve M2	5-40.20
Main Drive Gear Clutch Assembly	5-40.46
Main Drive Gear Clutch Brakes	5-36.2
Main Drive Gear Clutch Pads	5-36.1
Main Drive Motor	5-36.5
Main Drive Motor V-Belts	5-36.4
MC Unit Electronic Relays	5-40.36
MC Unit Motherboard	5-40.35
OCL Lamp(s)	5-30.3
P1 Block	5-40.18
P2 Block	5-40.19
Paper Cutter	5-40.50
Safety Bolt	5-40.48
Safety Bolt Proximity Switches	5-40.47
SCU Motherboard	5-40.34
SCU to MC Ribbon Cable	5-40.32
Right Light Barrier Assembly, Repair	5-40.51

INDEX - Cont

SUBJECT	PARAGRAPH
PAPER CUTTER (92-SD) - Cont	

S

Safety Bolt, Replace	5-40.48
Safety Bolt Proximity Switches, Replace	5-40.47
Safety Bolt Proximity Switches (SB. A and SB. E), Adjust	5-40.61
Safety Bolt Proximity Switches (SB.A and SB.E), Test	5-40.3
Service Hydraulic Fluid Filters	5-40.25
Service Upon Receipt	5-33
Services, Preventive Maintenance Checks and	5-25, 5-34
SCU Motherboard, Replace	5-40.34
SCU to MC Ribbon Cable, Replace	5-40.32
Shipment, Preparation for Storage or	5-37
Sledge Guides, Adjust	5-36.16
Solenoid Y27 (Clamp Ball Valve), Test	5-40.9
Solenoid Y33 (Cutting Ball Valve), Test	5-40.10
Solenoid Y315 (Locking Valve), Test	5-40.8

T

Table Lamp, Repair	5-36.13
Table Stop Bolt and Limit Switches, Adjust	5-36.17
Technical Principles of Operation	5-23
Troubleshooting	5-29, 5-35, 5-39
Test:	
AR Circuit Board for Input Power	5-40.15
Clamp Foot Pedal Switch (S309)	5-40.7
Clamp Proximity Switch (b29)	5-40.6
Cutting Buttons (S28a and b)	5-40.1
Gear Limit Switches (S22a and b)	5-40.5
HK Circuit Board for Input Power	5-40.12
IAR Circuit Board for Input Power	5-40.11
Inputs and Outputs of MC Unit Plug Connectors	5-40.16
KK Circuit Board for Input Power	5-40.14
Knife Changing Switch (S340)	5-40.13
Light Barrier Output/Inputs	5-40.2
Output of HK Board to Safety Bolt (Y.SB)	5-40.4
Safety Bolt Proximity Switches (SB. A and SB. E)	5-40.3
Solenoid Y27, (Clamp Ball Valve)	5-40.9
Solenoid Y33, (Cutting Ball Valve)	5-40.10
Solenoid Y315, (Locking Valve)	5-40.8

INDEX - Cont

SUBJECT	PARAGRAPH
PAPER DRILLING MACHINE	
C	
Components, Location and Description of Major	2-2.2
Conditions, Operation Under Unusual	2-7
Conditions, Operation Under Usual	2-6
Controls and Indicators, Description and Use of Operator's	2-4
Cord, Power, Replace.	2-16.2
D	
Data, Equipment	2-2.3
Description, Equipment	2-2
Description and Use of Operator's Controls and Indicators.	2-4
E	
Equipment Data.	2-2.3
Equipment Description	2-3
Equipment Characteristics, Capabilities, and Features.	2-2.1
G	
General Information	2-1
I	
Information, General	2-1
Instructions, Lubrication	2-8, 2-11
L	
Lamp, Replace	2-16.5
Lift Spring, Replace.	2-16.1
Location and Description of Major Components	2-2.2
Lubrication Instructions	2-8, 2-11
M	
Maintenance Procedures	2-10, 2-16
Motor, Replace.	2-16.3

INDEX - Cont

SUBJECT PARAGRAPH

PAPER DRILLING MACHINE - Cont

O

Operating Instructions on Decals and Instruction Plates	2-6.2
Operation, Technical Principles of	2-3
Operation Under Unusual Conditions	2-7
Operation Under Usual Conditions	2-6

P

Paper Drilling Machine, Remove/Install	2-16.7
Power Cord, Replace	2-16.2
Power Switch, Replace	2-16.4
Preparation For Storage or Shipment	2-17
Preventive Maintenance Checks and Services	2-5, 2-14
Procedures, Maintenance	2-10, 2-16

R

Remove/Install Paper Drilling Machine.	2-16.7
Replace:	
Lamp	2-16.5
Li ft Spring	2-16.1
Motor	2-16.3
Power Cord : :	2-16.2
Power Switch	2-16.4
Spi ndl e	2-16.6

S

Service Upon Receipt	2-13
Spi ndl e, Replace	2-16.6
Spring, Li ft, Replace	2-16.1
Shipment, Preparation for Storage or	2-17
Swi tch, Power, Replace	2-16.4

T

Techni cal Pri nci pl es of Operati on	2-3
Troubl eshooti ng	2-9, 2-15

INDEX - Cont

SUBJECT	PARAGRAPH
PAPER SHREDDER	
C	
Components, Location and Description of	4-2.2
Major	4-7
Conditions, Operation Under Unusual	4-6
Conditions, Operation Under Usual	4-20.9
Cooling Fan, Replace.	4-20.8
Cutting Head, Repair.	
D	
Data, Equipment	4-2.3
Description, Equipment	4-2
Description and Use of Operator's Controls and Indicators.	4-4
Direction, Switch, Replace	4-20.2
Drive Chain, Replace.	4-20.7
Drive Motor, Replace.	4-20.6
E	
Equipment Data.	4-2.3
Equipment Description	4-2
Equipment Characteristics, Capabilities, and Features	4-2.1
F	
Features, Equipment Characteristics, Capabilities, and	4-2.1
G	
General Information	4-1
I	
Indicators, Description and Use of Operator's Controls and	4-4
Information, General	4-1
Instructions, Lubrication	4-8, 4-11
K	
Key Switch, Replace	4-20.1

INDEX - Cont

SUBJECT	PARAGRAPH
PAPER SHREDDER - Cont	
L	
Location and Description of Major Components	4-2.2
Lubrication Instructions	4-8, 4-11
M	
Maintenance Procedures	4-10, 4-16, 4-20
O	
Operating Instructions on Decals and Instruction Plates	4-6.2
Operating Procedures	4-6.1
Operation, Technical Principles of	4-3
Operation Under Unusual Conditions	4-7
Operation Under Usual Conditions	4-6
P	
Paper Shredder, Remove/Install	4-20.10
Preparation for Storage or Shipment	4-17
Preventive Maintenance Checks and Services	4-5, 4-14
Procedures, Maintenance	4-10, 4-16, 4-20
Procedures, Operating	4-6.1
R	
Relay, Replace	4-20.4
Remove/Install Paper Shredder	4-20.10
Repair Cutting Head	4-20.8
Replace:	
Cooling Fan	4-20.9
Direction Switch	4-20.2
Drive Chain	4-20.7
Drive Motor	4-20.6
Key Switch	4-20.1
Relay	4-20.4
Safety Cover Switch	4-20.3
Wastebasket Overflow Switch	4-20.5
S	
Safety Cover Switch, Replace	4-20.3
Scope	4-1.1
Service Upon Receipt	4-13
Services, Preventive Maintenance Checks and	4-5, 4-14
Shipment, Preparation for Storage or	4-17

INDEX - Cont

SUBJECT
 PAPER SHREDDER - Cont

T

Technical Principles of Operation 4-3
 Troubleshooting 4-9, 4-15, 4-19

W

Wastebasket Overfill Switch, Replace 4-20.5

PAPER STITCHER

A

Adjust:

Both Staple Legs 3-10.5
 Clincher 3-10.5
 Control Collar 3-16.9
 Left Staple Leg 3-10.5
 Supporter Spring 3-10.6
 Work Table 3-6.1a

B

Bender Bar, Replace 3-16.3
 Both Staple Legs, Adjust 3-10.5

C

Change Driver 3-6.1d
 Clincher, Adjust 3-10.5
 Clutch Spring, Replace 3-16.8
 Components, Location and Description **of Major** 3-2.2
 Conditions, Operation Under Unusual 3-7
 Conditions, Operation Under Usual 3-6
 Control Collar, Adjust 3-16.9
 Controls and Indicators, Description **and** 3-4
 Use of Operator's 3-10.1
 Cutters, Wire, Replace

D

Data, Equipment 3-2.3
 Description, Equipment 3-2
 Description and Use of Operator's Controls
 and Indicators 3-4
 Driver Bar Latch, Replace 3-16.2
 Driver, Change 3-6.1d
 Driver, Replace 3-10.3

INDEX - Cont

SUBJECT
PAPER STITCHER - Cont

PARAGRAPH

E

Equipment Data 3-2.3
 Equipment Description 3-2
 Equipment Characteristics, Capabilities, and Features 3-2.1

F

Features, Equipment Characteristics, Capabilities, and 3-2.1

G

General Information 3-1
 Grip, Wire, Replace 3-10.2

I

Information, General 3-1
 Information, Reference 3-1.2
 Instructions, Lubrication 3-8, 3-11

L

Latch Driver Bar, Replace 3-16.2
 Left, Staple Leg, Adjust. 3-10.5
 Location and Description of Major Components 3-2.2
 Lubrication Instructions 3-8, 3-11

M

Maintenance Procedures 3-10, 3-16
 Microswitch, Replace 3-16.10
 Motor, Replace. 3-16.5

O

Operating Procedures 3-6.1
 Operation, Technical Principles of 3-3
 Operation Under Unusual Conditions 3-7
 Operation Under Usual Conditions 3-6
 Organizational Maintenance Procedures 3-16

INDEX - Cont

SUBJECT PARAGRAPH

PAPER STITCHER - Cont

P

Paper Stitcher, Remove/Install 3-16.11
 Preparation for Storage or Shipment 3-17
 Preventive Maintenance Checks and Services 3-5, 3-14
 Procedures, Maintenance 3-10, 3-16
 Procedures, Operating 3-6.1
 Power Switch, Replace 3-16.6

R

Reference Information 3-1.2
 Remove/Install Paper Stitcher 3-16.11
 Repair Switch 3-16.4
 Replace:
 Bender Bar 3-16.3
 Clutch Spring 3-16.8
 Driver 3-10.3
 Driver Bar Latch 3-16.2
 Microswitch 3-16.10
 Motor 3-16.5
 Power Switch 3-16.6
 Solenoid 3-16.7
 Supporter Spring 3-10.4
 V-Belt 3-16.1
 Wire Cutters 3-10.1
 Wire Grip 3-10.2

S

Scope 3-1.1
 Service Upon Receipt 3-13
 Solenoid, Replace 3-16.7
 Storage or Shipment, Preparation for 3-17
 Supporter Spring, Adjust 3-10.6
 Supporter Spring, Replace 3-10.4
 Switch, Repair 3-16.4

T

Technical Principles of Operation 3-3
 Thread, Wire 3-6.1e
 Troubleshooting 3-9, 3-15

V

V-Belt, Replace 3-16.1

INDEX - Cont

SUBJECT PARAGRAPH
 PAPER STITCHER - Cont

W

Wire Cutters, Replace	3-10.1
Wire Grip, Replace	3-10.2
Wire Thread ".	3-6.1e
Work Table, Adjust	3-6.1a

SHRINK WRAP

B

Brush and Spring, Replace	6-16.1
-------------------------------------	--------

C

Components, Location and Description of Major	6-2.2
Conditions, Operation Under Unusual	6-7
Conditions, Operation Under Usual	6-6
Control Switch, Replace	6-16.3
Control Switch, Service	6-5

D

Data, Equipment	6-2.3
Description Equipment	6-2
Description-and Use of Operator's Controls and Indicators	6-4

E

Equipment Data.	6-2.3
Equipment Description	6-2
Equipment Characteristics, Capabilities, and Features.	6-2.1

F

Features, Equipment Characteristics, Capabilities , and	6-2.1
---	-------

G

General Information	6-1
-------------------------------	-----

H

Heating Element, Replace	6-16.2
------------------------------------	--------

INDEX - Cont

SUBJECT PARAGRAPH

SHRINK WRAP - Cont

I

Indicators, Description and Use of Operator's
 Controls and 6-4
 Information, General 6-1
 Instructions, Lubrication 6-8, 6-11

L

Location and Description of Major Components 6-2.2
 Lubrication Instructions 6-8, 6-11

M

Maintenance Procedures 6-10, 6-16

O

Operation, Technical Principles of 6-3
 Operation Under Unusual Conditions 6-7
 Operation Under Usual Conditions 6-6

P

Preparation for Storage or Shipment 6-17
 Preventive Maintenance Checks and Services 6-5, 6-14
 Procedures, Maintenance 6-10, 6-16

R

Replace:
 Brush and Spring 6-16.1
 Control Switch 6-16.3
 Heating Element 6-16.2

S

Scope 6-1.1
 Service Control Switch 6-5
 Service Upon Receipt 6-13
 Services, Preventive Maintenance Checks and 6-5, 6-14
 Shipment, Preparation for Storage or 6-17

T

Technical Principles of Operation 6-3
 Troubleshooting 6-9, 6-15

INDEX - Cont

SUBJECT	PARAGRAPH
SUPPORT ITEMS	
A	
Assembly and Preparation for Use	9-6.1
D	
Description and Use of Operator's Controls and Indicators.	9-4
E	
Equipment Characteristics, Capabilities, and Features	9-2.1
G	
General Information	9-1
I	
Information, General	9-1
Instructions, Lubrication	9-8, 9-11
L	
Lubrication Instructions	9-8, 9-11
M	
Maintenance Procedures	9-10, 9-16
O	
Operation Under Unusual Conditions	9-7
Operation Under Usual Conditions	9-6
Operator's Controls and Indicators, Description and Use of	9-4
P	
Preparation for Storage or Shipment	9-17
Preparation for Use, Assembly and	9-6.1
Preventive Maintenance Checks and Services	9-5, 9-14
Procedures, Maintenance	9-10, 9-16
S	
Scope	9-1.1
Service Upon Receipt	9-13
Services, Preventive Maintenance Checks and	9-5, 9-14

INDEX - Cont

SUBJECT

PARAGRAPH

SUPPORT ITEMS - Cont

T

Technical Principles of Operation	9-3
Troubleshooting	9-9, 9-15

By Order of the Secretary of the Army:

JOHN A. WICKHAM, JR.
General, United States Army
Chief of Staff

Official:

DONALD J. DELANDRO
Brigadier General, United States Army
The Adjutant General

DISTRIBUTION:

To be distributed in accordance with DA Form 12-25A Operator's, Organizational, Direct Support and General Support Maintenance Requirements for Finishing Section, Topographic Support System, Model ADC-TSS-16 (TM 5-3610-253 Series).



THEN... JOT DOWN THE DOPE ABOUT IT ON THIS FORM. CAREFULLY TEAR IT OUT. FOLD IT AND DROP IT IN THE MAIL!

SOMETHING WRONG WITH THIS PUBLICATION?

FROM: (PRINT YOUR UNIT'S COMPLETE ADDRESS)
PFC JOHN DOE
COA, 3d ENGINEER BN
FT. LEANWOOD, MD 63108
 DATE SENT

PUBLICATION NUMBER: **TM 5-3610-253-14-2**
 PUBLICATION DATE: **3 Sep 85**
 PUBLICATION TITLE: **Topographic Support System Finishing Section**

BE EXACT... PIN-POINT WHERE IT IS				IN THIS SPACE TELL WHAT IS WRONG AND WHAT SHOULD BE DONE ABOUT IT:
PAGE NO	PARA-GRAPH	FIGURE NO	TABLE NO	
6	2-1 a			<i>In line 6 of paragraph 2-1a the manual states the engine has <u>6</u> cylinders. The engine on my set only has <u>4</u> cylinders. Change the manual to show <u>4</u> cylinders.</i>
B1		4-3		<i>Callout 16 on figure 4-3 is pointing at a <u>bolt</u>. In key to figure 4-3, item 16 is called a <u>shim</u> - Please correct one or the other.</i>
125	line 20			<i>I ordered a gasket, item 19 on figure B-16 by NSN 2 910-05-762-3001. I got a gasket but it doesn't fit. Supply says I got what I ordered, so the NSN is wrong. Please give me a good NSN</i>

PRINTED NAME, GRADE OR TITLE, AND TELEPHONE NUMBER: **JOHN DOE, PFC (268) 317-7111**
 SIGN HERE: **JOHN DOE**

TEAR ALONG PERFORATED LINE

FILL IN YOUR
UNIT'S ADDRESS

FOLD BACK

DEPARTMENT OF THE ARMY

OFFICIAL BUSINESS
PENALTY FOR PRIVATE USE \$300

POSTAGE AND FEES PAID
DEPARTMENT OF THE ARMY
DOD 314



TEAR ALONG PERFORATED LINE

COMMANDER
U S ARMY TROOP SUPPORT COMMAND
ATTN: AMSTR-MCTS
4300 GOODFELLOW BOULEVARD
ST. LOUIS, MO 63120-1798

FILL IN YOUR
UNIT'S ADDRESS

FOLD BACK

DEPARTMENT OF THE ARMY

OFFICIAL BUSINESS
PENALTY FOR PRIVATE USE \$300

POSTAGE AND FEES PAID
DEPARTMENT OF THE ARMY
DOD 314



TEAR ALONG PERFORATED LINE

COMMANDER
U S ARMY TROOP SUPPORT COMMAND
ATTN: AMSTR-MCTS
4300 GOODFELLOW BOULEVARD
ST. LOUIS, MO 63120-1798

RECOMMENDED CHANGES TO EQUIPMENT TECHNICAL PUBLICATIONS



THEN... JOT DOWN THE DOPE ABOUT IT ON THIS FORM. CAREFULLY TEAR IT OUT, FOLD IT AND DROP IT IN THE MAIL!

SOMETHING WRONG WITH THIS PUBLICATION?

FROM: (PRINT YOUR UNIT'S COMPLETE ADDRESS)

DATE SENT

PUBLICATION NUMBER

TM 5-3610-253-14-2

PUBLICATION DATE

3 Sep 85

PUBLICATION TITLE

Topographic Support Section
Finishing Section

BE EXACT... PIN-POINT WHERE IT IS

PAGE NO	PARA-GRAPH	FIGURE NO	TABLE NO
---------	------------	-----------	----------

IN THIS SPACE TELL WHAT IS WRONG AND WHAT SHOULD BE DONE ABOUT IT:

TEAR ALONG PERFORATED LINE

PRINTED NAME, GRADE OR TITLE, AND TELEPHONE NUMBER

SIGN HERE

DA FORM 2028-2
1 JUL 79

PREVIOUS EDITIONS ARE OBSOLETE.
DRSTS-M Overprint 2, 1 Nov 80.

P.S.--IF YOUR OUTFIT WANTS TO KNOW ABOUT YOUR RECOMMENDATION MAKE A CARBON COPY OF THIS AND GIVE IT TO YOUR HEADQUARTERS.

FILL IN YOUR
UNIT'S ADDRESS

FOLD BACK

DEPARTMENT OF THE ARMY

OFFICIAL BUSINESS
PENALTY FOR PRIVATE USE \$300

POSTAGE AND FEES PAID
DEPARTMENT OF THE ARMY
DOD 314



TEAR ALONG PERFORATED LINE

COMMANDER
U S ARMY TROOP SUPPORT COMMAND
ATTN: AMSTR-MCTS
4300 GOODFELLOW BOULEVARD
ST. LOUIS, MO 63120-1798

FILL IN YOUR
UNIT'S ADDRESS

FOLD BACK

DEPARTMENT OF THE ARMY

OFFICIAL BUSINESS
PENALTY FOR PRIVATE USE \$300

POSTAGE AND FEES PAID
DEPARTMENT OF THE ARMY
DOD 314



TEAR ALONG PERFORATED LINE

COMMANDER
U S ARMY TROOP SUPPORT COMMAND
ATTN: AMSTR-MCTS
4300 GOODFELLOW BOULEVARD
ST. LOUIS, MO 63120-1798

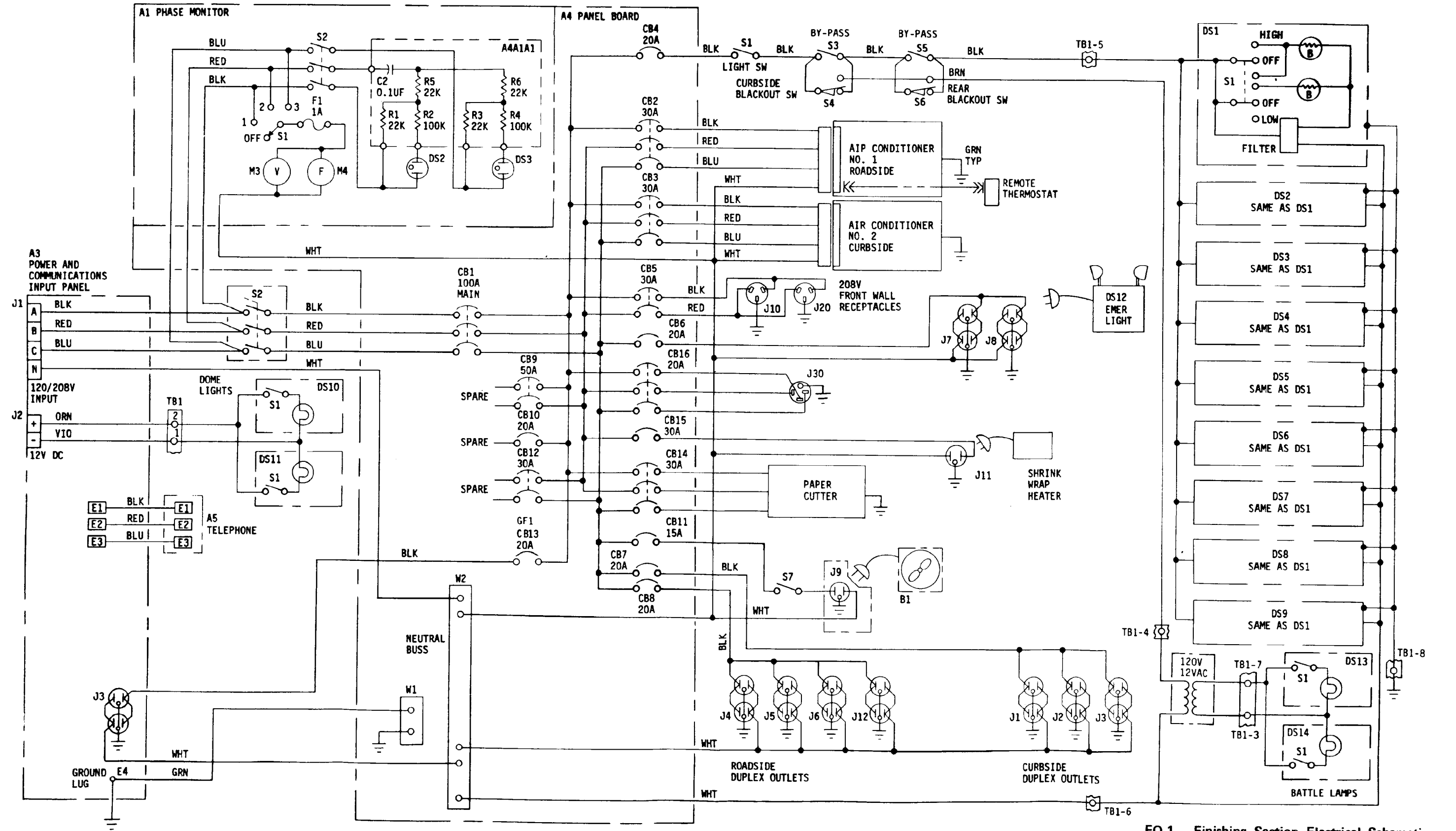

FO-1. Finishing Section Electrical Schematic

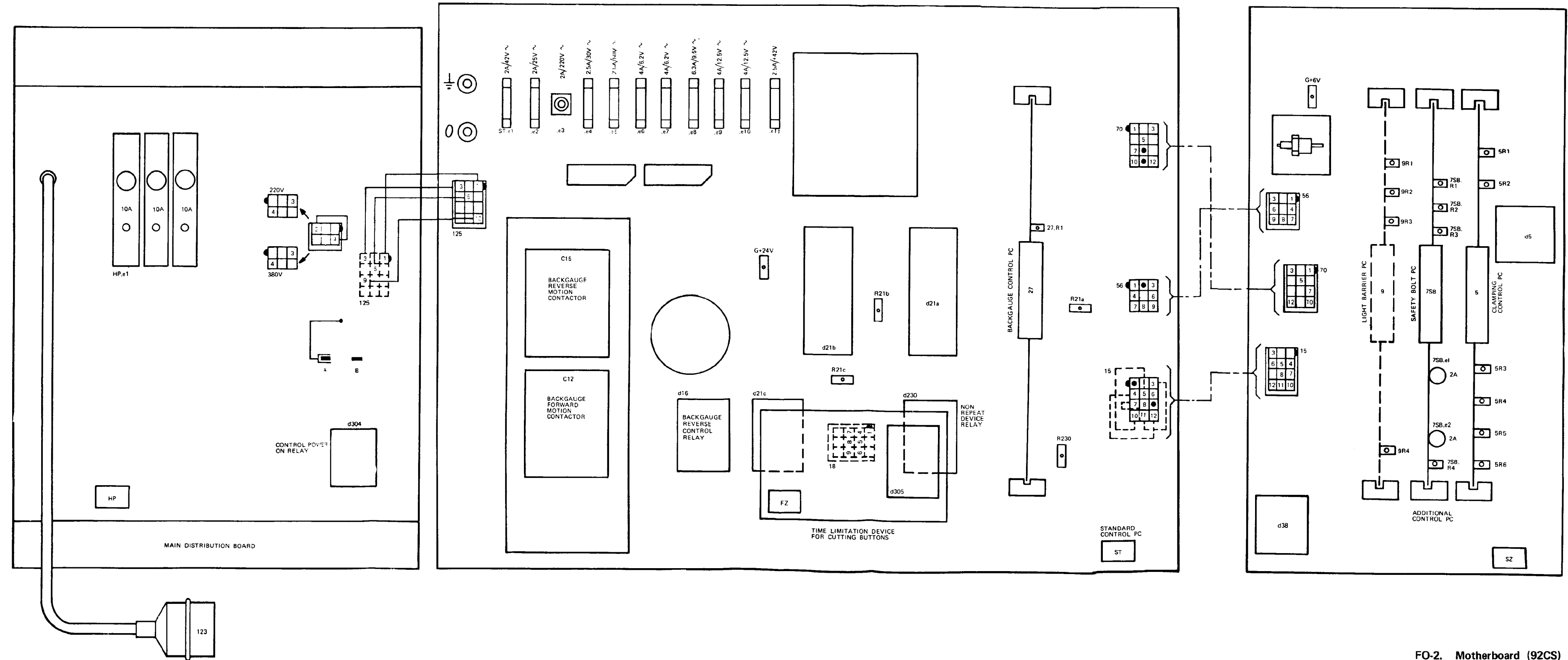

FO-2. Motherboard (92CS)

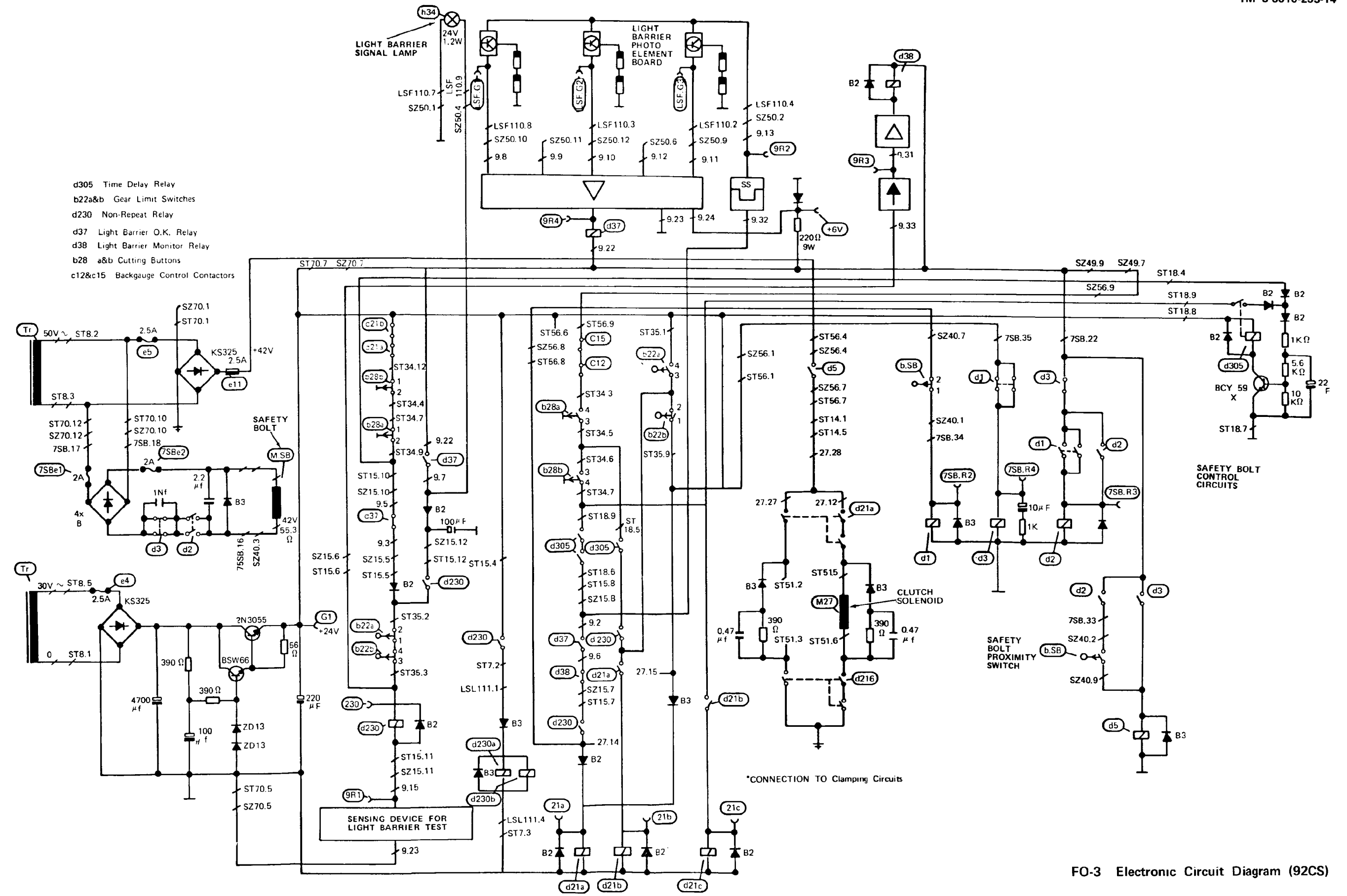

FO-3 Electronic Circuit Diagram (92CS)

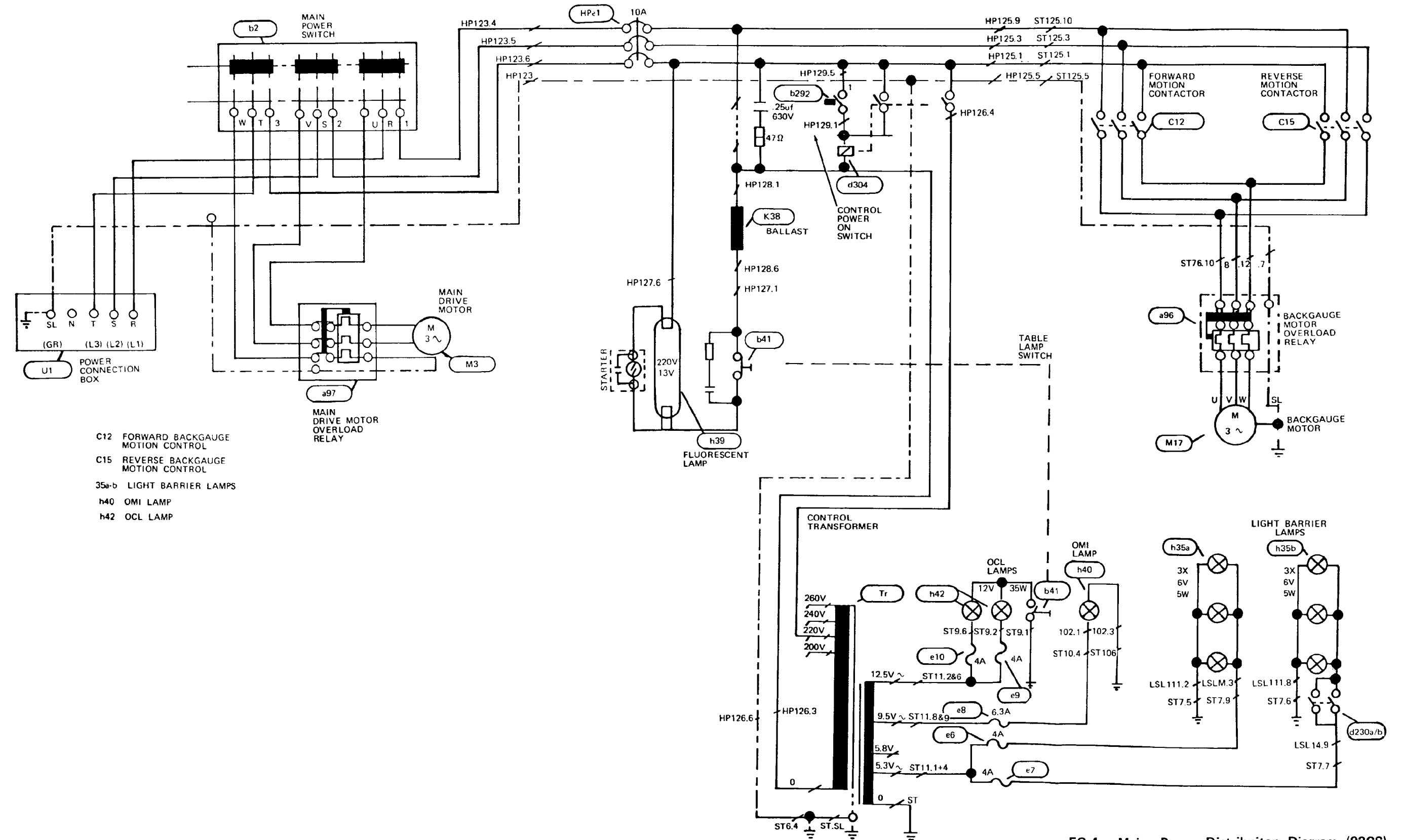

- C12 FORWARD BACKGAUGE MOTION CONTROL
- C15 REVERSE BACKGAUGE MOTION CONTROL
- 35a-b LIGHT BARRIER LAMPS
- h40 OMI LAMP
- h42 OCL LAMP

FO-4. Major Power Distribution Diagram (92CS)

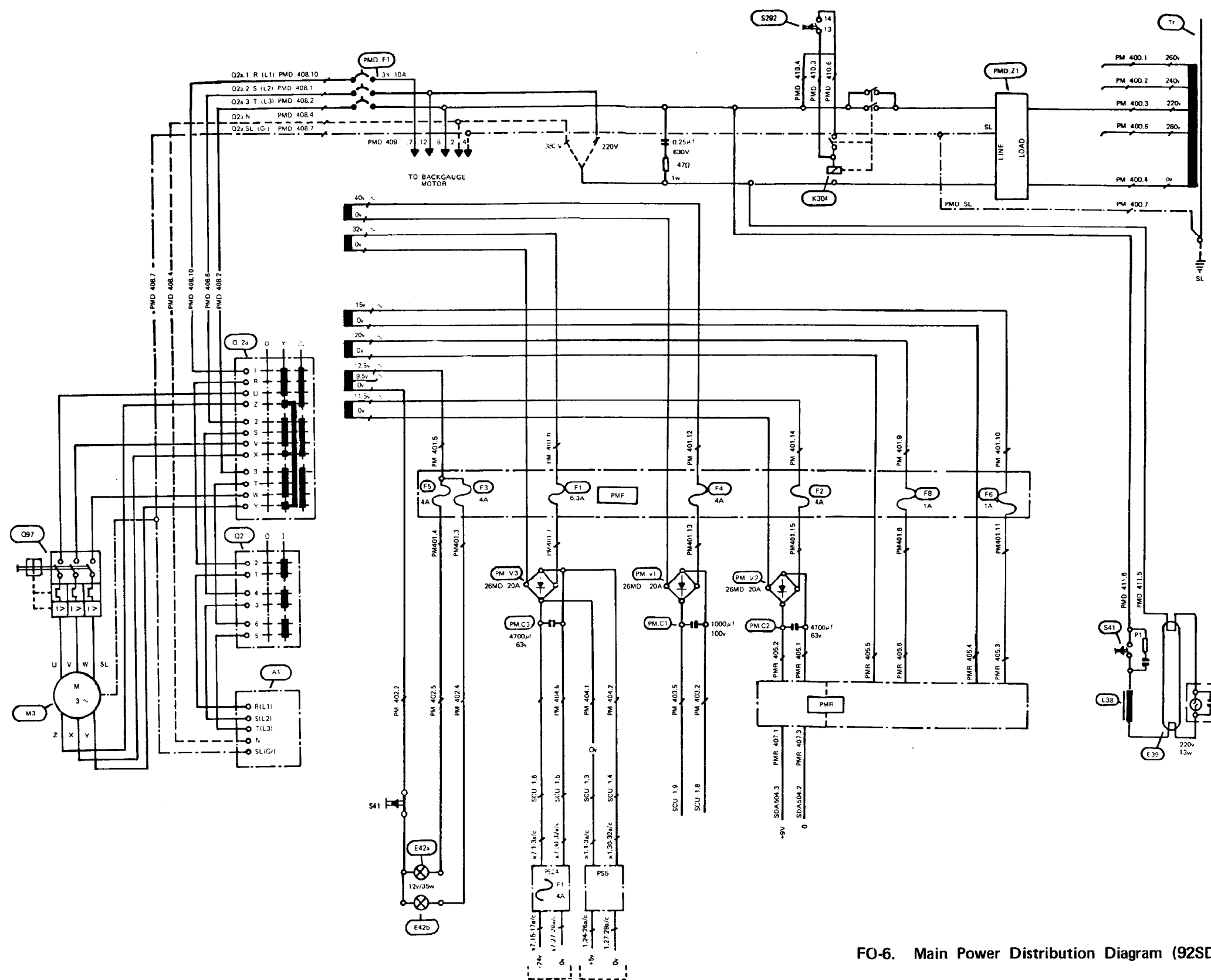

FO-6. Main Power Distribution Diagram (92SD)

The Metric System and Equivalents

Linear Measure

1 centimeter = 10 millimeters = .39 inch
 1 decimeter = 10 centimeters = 3.94 inches
 1 meter = 10 decimeters = 39.37 inches
 1 dekameter = 10 meters = 32.8 feet
 1 hectometer = 10 dekameters = 328.08 feet
 1 kilometer = 10 hectometers = 3,280.8 feet

Weights

1 centigram = 10 milligrams = .15 grain
 1 decigram = 10 centigrams = 1.54 grains
 1 gram = 10 decigram = .035 ounce
 1 dekagram = 10 grams = .35 ounce
 1 hectogram = 10 dekagrams = 3.52 ounces
 1 kilogram = 10 hectograms = 2.2 pounds
 1 quintal = 100 kilograms = 220.46 pounds
 1 metric ton = 10 quintals = 1.1 short tons

Liquid Measure

1 centiliter = 10 milliliters = .34 fl. ounce
 1 deciliter = 10 centiliters = 3.38 fl. ounces
 1 liter = 10 deciliters = 33.81 fl. ounces
 1 dekaliter = 10 liters = 2.64 gallons
 1 hectoliter = 10 dekaliters = 26.42 gallons
 1 kiloliter = 10 hectoliters = 264.18 gallons

Square Measure

1 sq. centimeter = 100 sq. millimeters = .155 sq. inch
 1 sq. decimeter = 100 sq. centimeters = 15.5 sq. inches
 1 sq. meter (centare) = 100 sq. decimeters = 10.76 sq. feet
 1 sq. dekameter (are) = 100 sq. meters = 1,076.4 sq. feet
 1 sq. hectometer (hectare) = 100 sq. dekameters = 2.47 acres
 1 sq. kilometer = 100 sq. hectometers = .386 sq. mile

Cubic Measure

1 cu. centimeter = 1000 cu. millimeters = .06 cu. inch
 1 cu. decimeter = 1000 cu. centimeters = 61.02 cu. inches
 1 cu. meter = 1000 cu. decimeters = 35.31 cu. feet

Approximate Conversion Factors

To change	To	Multiply by	To change	To	Multiply by
inches	centimeters	2.540	ounce-inches	newton-meters	.007062
feet	meters	.305	centimeters	inches	.394
yards	meters	.914	meters	feet	3.280
miles	kilometers	1.609	meters	yards	1.094
square inches	square centimeters	6.451	kilometers	miles	.621
square feet	square meters	.093	square centimeters	square inches	.155
square yards	square meters	.836	square meters	square feet	10.764
square miles	square kilometers	2.590	square meters	square yards	1.196
acres	square hectometers	.405	square kilometers	square miles	.386
cubic feet	cubic meters	.028	square hectometers	acres	2.471
cubic yards	cubic meters	.765	cubic meters	cubic feet	35.315
fluid ounces	milliliters	29.573	cubic meters	cubic yards	1.308
pints	liters	.473	milliliters	fluid ounces	.034
quarts	liters	.946	liters	pints	2.113
gallons	liters	3.785	liters	quarts	1.057
ounces	grams	28.349	liters	gallons	.264
pounds	kilograms	.454	grams	ounces	.035
short tons	metric tons	.907	kilograms	pounds	2.205
pound-feet	newton-meters	1.356	kilograms	short tons	1.102
pound-inches	newton-meters	.11296	metric tons		

Temperature (Exact)

°F	Fahrenheit temperature	5/9 (after subtracting 32)	Celsius temperature	°C
----	------------------------	----------------------------	---------------------	----

